

# Operating Instructions Manual

## ProMinent® gamma/ L

### Solenoid Metering Pump



GALA \_\_\_\_\_

Please enter ident code of the device here

**Please read the operating instructions through completely before commissioning this equipment! Do not discard!  
Any part which has been subject to misuse is excluded from the warranty!**

**Printing:**

Operating Instructions ProMinent® gamma/ L  
© ProMinent Dosiertechnik GmbH, 1999

Address:

ProMinent Dosiertechnik GmbH  
Im Schuhmachergewann 5-11  
69123 Heidelberg  
Germany  
info@prominent.com  
www.prominent.com

Subject to technical alteration.

Please fold out this page! 

Control elements: overview

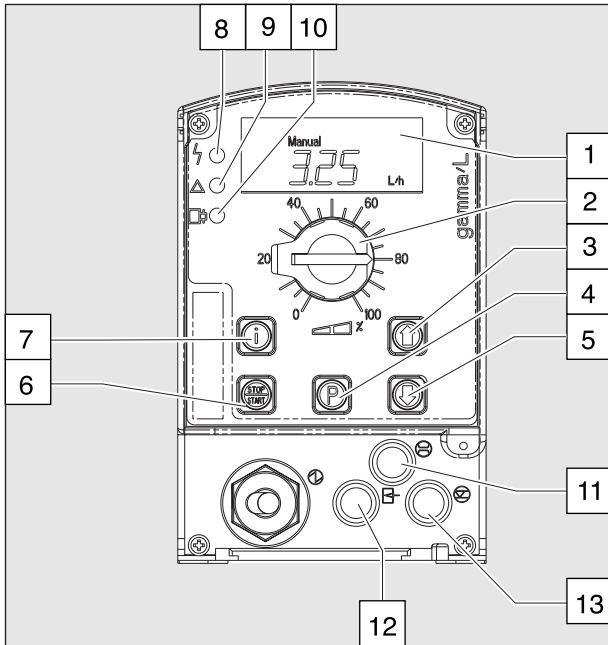

- 1 LCD display
- 2 Stroke length adjusting knob
- 3 UP key
- 4 P key
- 5 DOWN key
- 6 STOP/START key
- 7 i key
- 8 Fault indicator (red)
- 9 Warning indicator (yellow)
- 10 Operating indicator (green)
  
- 11 "Dosing monitor" terminal
- 12 "External control" terminal
- 13 "Float switch" terminal

Key functions

In continuous display mode (operating)

In settings mode (settings)

STOP/START key



Press briefly

Stop pump, start pump

Stop pump, start pump

P key



Press briefly

Start batch (in "batch" operating mode only),  
Cancel error

Confirm entry- jump to next menu option or continuous display

Press for 2 s

Change to settings mode

---

Press for 3 s

---

Jump to continuous display

Press for 10 s

Display software version

---

Press for 15 s

Load factory settings (calibration)

---

Touche i



Press x1

Toggle between continuous displays

Toggle between "change individual digits" and change a figure"

Press x2

---

For "change individual digits": jumps to first digit

Arrow keys UP and DOWN



Press x1 (until "Set" appears)

Change directly alterable values

Select other settings, change individual digit or figure

Press simultaneously

Prime

---



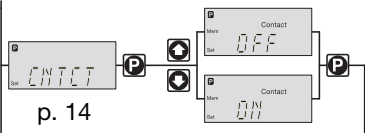

p. 14

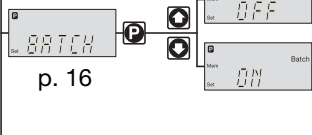
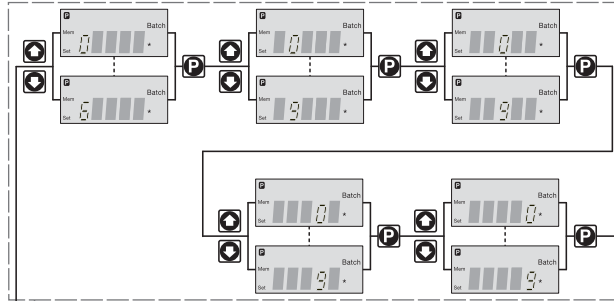
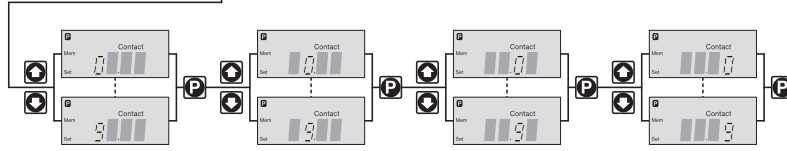

p. 16

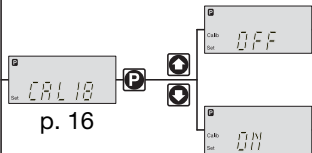
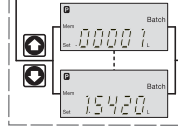

p. 16

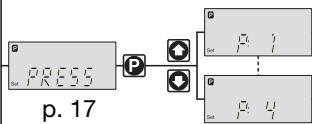
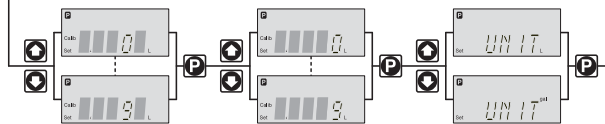
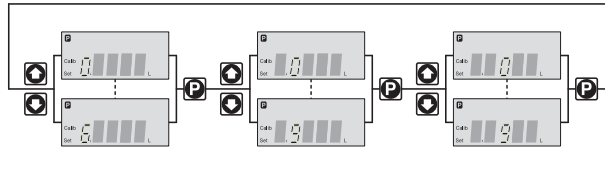
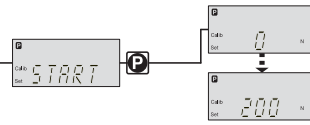

p. 17

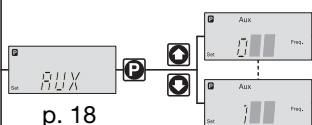

p. 18

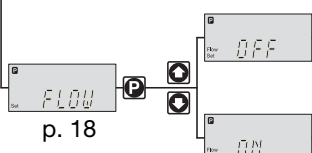
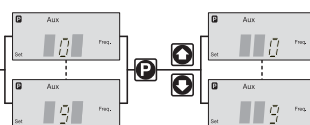



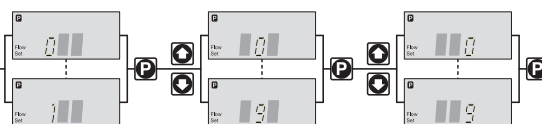





















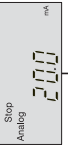

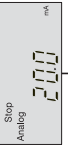

p. 18



p. 19

# Continuous display

|                              | Operating mode "Analog" 0-20 mA   | Operating mode "Manual"   | Operating mode "Contact" with memory and transfer factor 5                          | Operating mode "Batch" with memory and transfer factor 5                            |
|------------------------------|---|---|---|---|
| Stroke rate                  |    |    |    |    |
| Feed rate                    |    |    |    |    |
| Total stroke number          |    |    |    |    |
| Total litres (feed quantity) |    |    |    |    |
| "External" display           |    |  |  |  |
| Signal current               |    |  |  |  |
| Strokes remaining            |   |   |   |   |
| Batch size/ Litres remaining |   |   |   |   |
| Factor                       |   |   |   |   |
| Stroke length                |  |  |  |  |

⬆️⬆️ = UP and/or DOWN arrow keys, directly alterable values

"Mem" appears only when "memory" function activated

## Table of Contents

|  |           |
|--|-----------|
| Identcode .....  | 9         |
| General User Guidelines .....  | 10        |
| <b>1 About This Pump .....</b>                                       | <b>11</b> |
| <b>2 Safety .....</b>  | <b>11</b> |
| <b>3 Storage, Transport and Unpacking .....</b>                      | <b>12</b> |
| <b>4 Device Overview and Control elements .....</b>                  | <b>12</b> |
| 4.1 Device overview .....  | 12        |
| 4.2 Control elements .....   | 13        |
| <b>5 Function Description .....</b>                                  | <b>13</b> |
| <b>6 Assembly and Installation .....</b>                             | <b>16</b> |
| 6.1 Retrofitting relays .....  | 19        |
| <b>7 Settings .....</b>  | <b>21</b> |
| 7.1 Check adjustable values .....                                    | 22        |
| 7.2 Change to settings mode .....                                    | 22        |
| 7.3 Select operating mode (MODE menu) .....                          | 23        |
| 7.4 Settings for operating mode (SET menu) .....                     | 23        |
| 7.4.1 Settings for “manual” operating mode .....                     | 23        |
| 7.4.2 Settings for “analogue” operating mode (ANALG menu) .....      | 23        |
| 7.4.3 Settings for “contact” operating mode (CONTCT menu) .....      | 25        |
| 7.4.4 Settings for “batch” operating mode (BATCH menu) .....         | 27        |
| 7.5 Settings for programmable functions (SET menu) .....             | 28        |
| 7.5.1 Settings for “calibration” function (CALIB menu) .....         | 28        |
| 7.5.2 Settings for the “pressure levels” function (PRESS menu) ..... | 29        |
| 7.5.3 Settings for “auxiliary frequency” function (AUX menu) .....   | 29        |
| 7.5.4 Settings for the “flow” function (FLOW menu) .....             | 30        |
| 7.6 Setting code (CODE menu) .....                                   | 30        |
| 7.7 Cancel total stroke number or total litres (CLEAR window) .....  | 30        |
| <b>8 Operating .....</b>   | <b>31</b> |
| 8.1 Manual operation .....   | 31        |
| <b>9 Maintenance .....</b>   | <b>33</b> |
| <b>10 Repairs .....</b>  | <b>33</b> |
| <b>11 Troubleshooting .....</b>                                      | <b>38</b> |
| Error Messages .....   | 38        |
| Fault Signals .....  | 39        |
| <b>12 Decommissioning and Disposal .....</b>                         | <b>39</b> |

|  |           |
|--|-----------|
| <b>13 Technical Data</b> .....               | <b>40</b> |
| 13.1 Performance data and weights .....      | 40        |
| 13.2 Dosing reproducibility .....            | 41        |
| 13.3 Viscosity .....                         | 41        |
| 13.4 Materials Data Liquid ends .....        | 41        |
| 13.5 Electrical Data .....                   | 41        |
| 13.6 Ambient conditions .....                | 42        |
| 13.7 Enclosure rating and safety class ..... | 42        |
| 13.8 Compatibility .....                     | 42        |
| <b>Annexe</b> .....                          | <b>43</b> |
| gamma/ L Dimensions .....                    | 43        |
| Exploded diagrams of liquid ends .....       | 47        |
| Feed rate settings diagrams .....            | 67        |
| EC-Declaration of Conformity .....           | 70        |



Identcode

Please enter the identity code on the device label into the grey box below

| GALA  |   | GALA Series gamma/ L, version a |                   |      |  |  |  |  |  |  |  |  |  |  |  |  |  |  |  |  |  |  |  |
|---|---|---------------------------------|-------------------|------|--|--|--|--|--|--|--|--|--|--|--|--|--|--|--|--|--|--|--|
| Type  | Capacity  |                                 | Solenoid Ø 70/M70 |      |  |  |  |  |  |  |  |  |  |  |  |  |  |  |  |  |  |  |  |
|   | bar   | l/h                             |                   |      |  |  |  |  |  |  |  |  |  |  |  |  |  |  |  |  |  |  |  |
|   | 1000  | 10 0.74                         |                   |      |  |  |  |  |  |  |  |  |  |  |  |  |  |  |  |  |  |  |  |
|   | 1601  | 16 1.1                          |                   |      |  |  |  |  |  |  |  |  |  |  |  |  |  |  |  |  |  |  |  |
|   | 1602  | 16 2.1                          |                   |      |  |  |  |  |  |  |  |  |  |  |  |  |  |  |  |  |  |  |  |
|   | 1005  | 10 4.4                          |                   |      |  |  |  |  |  |  |  |  |  |  |  |  |  |  |  |  |  |  |  |
|   | 0708  | 7 7.1                           |                   |      |  |  |  |  |  |  |  |  |  |  |  |  |  |  |  |  |  |  |  |
|   | 0413  | 4 12.3                          |                   |      |  |  |  |  |  |  |  |  |  |  |  |  |  |  |  |  |  |  |  |
|   | 0220  | 2 19.0                          |                   |      |  |  |  |  |  |  |  |  |  |  |  |  |  |  |  |  |  |  |  |
|   | 1605  | 16 4.1                          |                   |      |  |  |  |  |  |  |  |  |  |  |  |  |  |  |  |  |  |  |  |
|   | 1008  | 10 6.8                          |                   |      |  |  |  |  |  |  |  |  |  |  |  |  |  |  |  |  |  |  |  |
|   | 0713  | 7 11.0                          |                   |      |  |  |  |  |  |  |  |  |  |  |  |  |  |  |  |  |  |  |  |
|   | 0420  | 4 17.1                          |                   |      |  |  |  |  |  |  |  |  |  |  |  |  |  |  |  |  |  |  |  |
|   | 0232  | 2 32.0                          |                   |      |  |  |  |  |  |  |  |  |  |  |  |  |  |  |  |  |  |  |  |
|   |   | Solenoid Ø 85/M85               |                   |      |  |  |  |  |  |  |  |  |  |  |  |  |  |  |  |  |  |  |  |
| <b>Material version:</b>  |   |                                 |                   |      |  |  |  |  |  |  |  |  |  |  |  |  |  |  |  |  |  |  |  |
| PPE   | Polypropylene/EPDM  |                                 |                   |      |  |  |  |  |  |  |  |  |  |  |  |  |  |  |  |  |  |  |  |
| PPB   | Polypropylene/FPM   |                                 |                   |      |  |  |  |  |  |  |  |  |  |  |  |  |  |  |  |  |  |  |  |
| NPE   | Acrylic glass/EPDM  |                                 |                   |      |  |  |  |  |  |  |  |  |  |  |  |  |  |  |  |  |  |  |  |
| NPB   | Acrylic glass/FPM   |                                 |                   |      |  |  |  |  |  |  |  |  |  |  |  |  |  |  |  |  |  |  |  |
| PVT   | PVDF/PTFE   |                                 |                   |      |  |  |  |  |  |  |  |  |  |  |  |  |  |  |  |  |  |  |  |
| TTT   | PTFE/PTFE   |                                 |                   |      |  |  |  |  |  |  |  |  |  |  |  |  |  |  |  |  |  |  |  |
| SST   | Stainless steel 1.4571/PTFE   |                                 |                   |      |  |  |  |  |  |  |  |  |  |  |  |  |  |  |  |  |  |  |  |
| <b>Liquid end version:</b>  |   |                                 |                   |      |  |  |  |  |  |  |  |  |  |  |  |  |  |  |  |  |  |  |  |
| 0   | Non-bleed, no valve spring, for NP, TT and SS only  |                                 |                   |      |  |  |  |  |  |  |  |  |  |  |  |  |  |  |  |  |  |  |  |
| 1   | Non-bleed, with valve spring, for NP, TT and SS only                                      |                                 |                   |      |  |  |  |  |  |  |  |  |  |  |  |  |  |  |  |  |  |  |  |
| 2   | Bleed function, no valve spring for PP, NP, PV, not type 0232                             |                                 |                   |      |  |  |  |  |  |  |  |  |  |  |  |  |  |  |  |  |  |  |  |
| 3   | Bleed function, no valve spring for PP, NP, PV, not type 0232                             |                                 |                   |      |  |  |  |  |  |  |  |  |  |  |  |  |  |  |  |  |  |  |  |
| 4   | No-vent with valve springs for highly viscous media                                       |                                 |                   |      |  |  |  |  |  |  |  |  |  |  |  |  |  |  |  |  |  |  |  |
| 9   | Self bleed function, for PP, NP, not for type 1000 and 0232                               |                                 |                   |      |  |  |  |  |  |  |  |  |  |  |  |  |  |  |  |  |  |  |  |
| <b>Hydraulic connection:</b>  |   |                                 |                   |      |  |  |  |  |  |  |  |  |  |  |  |  |  |  |  |  |  |  |  |
| 0   | Standard connector as indicated in technical data   |                                 |                   |      |  |  |  |  |  |  |  |  |  |  |  |  |  |  |  |  |  |  |  |
| 5   | 12/6 hose connector, pressure side only   |                                 |                   |      |  |  |  |  |  |  |  |  |  |  |  |  |  |  |  |  |  |  |  |
| 9   | 10/4 hose connector, pressure side only   |                                 |                   |      |  |  |  |  |  |  |  |  |  |  |  |  |  |  |  |  |  |  |  |
| <b>Version:</b>   |   |                                 |                   |      |  |  |  |  |  |  |  |  |  |  |  |  |  |  |  |  |  |  |  |
| 0   | With ProMinent® logo  |                                 |                   |      |  |  |  |  |  |  |  |  |  |  |  |  |  |  |  |  |  |  |  |
| <b>Power supply:</b>  |   |                                 |                   |      |  |  |  |  |  |  |  |  |  |  |  |  |  |  |  |  |  |  |  |
| U   | 100 - 230 V, ±10 %, 50/60 Hz  |                                 |                   |      |  |  |  |  |  |  |  |  |  |  |  |  |  |  |  |  |  |  |  |
| M   | 12...24 V DC (only M 70)  |                                 |                   |      |  |  |  |  |  |  |  |  |  |  |  |  |  |  |  |  |  |  |  |
| N   | 24 V DC (only M 85)   |                                 |                   |      |  |  |  |  |  |  |  |  |  |  |  |  |  |  |  |  |  |  |  |
| P   | 24 V AC   |                                 |                   |      |  |  |  |  |  |  |  |  |  |  |  |  |  |  |  |  |  |  |  |
| <b>Cable and plug:</b>  |   |                                 |                   |      |  |  |  |  |  |  |  |  |  |  |  |  |  |  |  |  |  |  |  |
| A   | 2 m Euro  |                                 |                   |      |  |  |  |  |  |  |  |  |  |  |  |  |  |  |  |  |  |  |  |
| B   | 2 m Swiss   |                                 |                   |      |  |  |  |  |  |  |  |  |  |  |  |  |  |  |  |  |  |  |  |
| C   | 2 m Australian  |                                 |                   |      |  |  |  |  |  |  |  |  |  |  |  |  |  |  |  |  |  |  |  |
| D   | 2 m USA   |                                 |                   |      |  |  |  |  |  |  |  |  |  |  |  |  |  |  |  |  |  |  |  |
| 1   | 2 m open end  |                                 |                   |      |  |  |  |  |  |  |  |  |  |  |  |  |  |  |  |  |  |  |  |
| <b>Relay:</b>   |   |                                 |                   |      |  |  |  |  |  |  |  |  |  |  |  |  |  |  |  |  |  |  |  |
| 0   | No relay  |                                 |                   |      |  |  |  |  |  |  |  |  |  |  |  |  |  |  |  |  |  |  |  |
| 1   | Fault indicating relay, (N/C) changeover relay  |                                 |                   |      |  |  |  |  |  |  |  |  |  |  |  |  |  |  |  |  |  |  |  |
| 3   | Fault indicating relay, (N/O) changeover relay  |                                 |                   |      |  |  |  |  |  |  |  |  |  |  |  |  |  |  |  |  |  |  |  |
| 4   | As 1 + pacing relay, (1 input each)   |                                 |                   |      |  |  |  |  |  |  |  |  |  |  |  |  |  |  |  |  |  |  |  |
| 5   | As 3 + pacing relay, (1 input each)   |                                 |                   |      |  |  |  |  |  |  |  |  |  |  |  |  |  |  |  |  |  |  |  |
| <b>Accessories:</b>   |   |                                 |                   |      |  |  |  |  |  |  |  |  |  |  |  |  |  |  |  |  |  |  |  |
| 0   | No accessories  |                                 |                   |      |  |  |  |  |  |  |  |  |  |  |  |  |  |  |  |  |  |  |  |
| 1   | Foot and dosing valve, 2 m PVC suction tube, 5 m PE discharge tubing, PP, PC, and NP only |                                 |                   |      |  |  |  |  |  |  |  |  |  |  |  |  |  |  |  |  |  |  |  |
| 2   | As 0 + calibrating cylinder   |                                 |                   |      |  |  |  |  |  |  |  |  |  |  |  |  |  |  |  |  |  |  |  |
| 3   | As 1 + calibrating cylinder   |                                 |                   |      |  |  |  |  |  |  |  |  |  |  |  |  |  |  |  |  |  |  |  |
| <b>Control variants:</b>  |   |                                 |                   |      |  |  |  |  |  |  |  |  |  |  |  |  |  |  |  |  |  |  |  |
| 0   | Manual + external 1:1   |                                 |                   |      |  |  |  |  |  |  |  |  |  |  |  |  |  |  |  |  |  |  |  |
| 1   | Manual + external with pulse control  |                                 |                   |      |  |  |  |  |  |  |  |  |  |  |  |  |  |  |  |  |  |  |  |
| 2   | Manual + external 1:1 with analogue current   |                                 |                   |      |  |  |  |  |  |  |  |  |  |  |  |  |  |  |  |  |  |  |  |
| 3   | Manual + external with pulse control + analogue current                                   |                                 |                   |      |  |  |  |  |  |  |  |  |  |  |  |  |  |  |  |  |  |  |  |
| 4   | as 0 + timer  |                                 |                   |      |  |  |  |  |  |  |  |  |  |  |  |  |  |  |  |  |  |  |  |
| 5   | as 3 + timer  |                                 |                   |      |  |  |  |  |  |  |  |  |  |  |  |  |  |  |  |  |  |  |  |
| P   | as 3 + Profibus®  |                                 |                   |      |  |  |  |  |  |  |  |  |  |  |  |  |  |  |  |  |  |  |  |
| <b>Access code:</b>   |   |                                 |                   |      |  |  |  |  |  |  |  |  |  |  |  |  |  |  |  |  |  |  |  |
| 0   | No access code  |                                 |                   |      |  |  |  |  |  |  |  |  |  |  |  |  |  |  |  |  |  |  |  |
| 1   | Access code   |                                 |                   |      |  |  |  |  |  |  |  |  |  |  |  |  |  |  |  |  |  |  |  |
| <b>Dosing monitoring:</b>   |   |                                 |                   |      |  |  |  |  |  |  |  |  |  |  |  |  |  |  |  |  |  |  |  |
| 0   | Pulse input   |                                 |                   |      |  |  |  |  |  |  |  |  |  |  |  |  |  |  |  |  |  |  |  |
| 1   | Input for continuous contact  |                                 |                   |      |  |  |  |  |  |  |  |  |  |  |  |  |  |  |  |  |  |  |  |
| <b>Pause/level:</b>   |   |                                 |                   |      |  |  |  |  |  |  |  |  |  |  |  |  |  |  |  |  |  |  |  |
| 0   | Pause N/C level N/C   |                                 |                   |      |  |  |  |  |  |  |  |  |  |  |  |  |  |  |  |  |  |  |  |
| FPM = Fluorkautschuk  |   |                                 |                   |      |  |  |  |  |  |  |  |  |  |  |  |  |  |  |  |  |  |  |  |
| <table border="1" style="width: 100%; height: 20px;"> <tr> <td style="width: 10%;">GALA</td> <td style="width: 10%;"></td> <td style="width: 10%;"></td> <td style="width: 10%;"></td> <td style="width: 10%;"></td> <td style="width: 10%;"></td> <td style="width: 10%;"></td> <td style="width: 10%;"></td> <td style="width: 10%;"></td> <td style="width: 10%;"></td> <td style="width: 10%;"></td> <td style="width: 10%;"></td> <td style="width: 10%;"></td> <td style="width: 10%;"></td> <td style="width: 10%;"></td> <td style="width: 10%;"></td> <td style="width: 10%;"></td> <td style="width: 10%;"></td> <td style="width: 10%;"></td> <td style="width: 10%;"></td> </tr> </table> |   |                                 |                   | GALA |  |  |  |  |  |  |  |  |  |  |  |  |  |  |  |  |  |  |  |
| GALA  |   |                                 |                   |      |  |  |  |  |  |  |  |  |  |  |  |  |  |  |  |  |  |  |  |

### General User Guidelines

Please read through the following user Guidelines. Familiarity with these points ensures optimum use of the operating instructions.

On the fold-out page after the title page you will find the overviews “control elements and key functions” and “operating/settings diagrams”.

You will find it useful to open out the “control elements and key functions” overview as you read this instruction manual.

Key points in the text are indicated as follows:

- Enumerated points
- ▶ Hints

Working Guidelines:

#### **NOTE**

**Guidelines are intended to make your work easier.**

Safety Guidelines:



#### **WARNING**

**Describes a potentially dangerous situation.  
Could result in loss of life or serious injury if preventative measures are not taken.**



#### **CAUTION**

**Describes a potentially dangerous situation.  
Could result in lesser injuries or damage to property if preventative measures are not taken.**



#### **IMPORTANT**

**Describes a potentially threatening situation.  
Could result in damage to property if preventative measures are not taken.**

The name plate affixed to the title page is identical to that on the gamma/ L pump supplied. This facilitates matching the correct operating instructions manual to the correct pump.

Please quote the identity code and the serial number, which you will find on the name plate, in any subsequent correspondence or when ordering spare parts. This will ensure accurate identification of the pump type and material version.

## 1 About This Pump

The pumps in the ProMinent® gamma/ L pump series are microprocessor controlled solenoid dosing pumps with the following special features:

- The feed rate can be displayed in l/h and/or gal/h (calibrated), or in strokes/min.
- The stroke rate is continuously adjustable and is displayed in the LCD display.
- Stroke rate adjustment is digitally accurate and is displayed in the LCD display.
- The rated pressure of the gamma/ L can be adapted to individual systems.
- Two pumps can be controlled in different ways via the same standard signal.
- Large, illuminated LCD display

The hydraulic parts of the gamma/ L are identical to those of the Beta®.

## 2 Safety

*Correct use* The gamma/ L must be used for liquids only!  
The gamma/ L may be used only in compliance with the technical data and specifications given in the operating instructions!  
It is forbidden to use the gamma/ L for any other purpose, or to modify it in any way!  
The gamma/ L is not suitable for dosing gases or solids!  
The gamma/ L must be used by trained and authorised personnel only!

### Safety Guidelines



#### WARNING

- **As soon as the gamma/ L is connected to the electricity supply it may commence pumping!  
Avoid leakage of hazardous chemicals in this case!  
If this should occur, then press the STOP/START key or disconnect the gamma/ L from the power supply immediately!**
- **The gamma/ L cannot be switched to a current-free status! In the event of an electrical accident, disconnect cable from the mains power supply!**
- **Disconnect cable from the mains power supply before commencing work on the gamma/ L!**
- **Always depressurise liquid end before commencing work on the gamma/ L!**
- **Empty and rinse out the liquid end before commencing work on the gamma/ L after use with hazardous or unknown chemicals!**
- **Pumps for radioactive materials may not be returned to ProMinent after use!**



#### CAUTION

- **It is not permitted to assemble and install ProMinent® dosing pumps with non-original parts unless these have been checked and recommended by ProMinent. It can result in harm to persons and property for which no liability will be accepted!**
- **When dosing aggressive materials, check the resistance of the pump materials (see ProMinent® resistance list in the product catalogue!)**
- **If another liquid end size is installed the pump must be reprogrammed on factory premises!**
- **Observe applicable national directives during installation!**

*Sound intensity level* The sound intensity level is < 70 dB (A) at maximum stroke, maximum stroke rate, maximum back pressure (water) in accordance with:  
DIN EN 12639 (Metering Pump Noise Measurement)

### 3 Storage, Transport and Unpacking

Transport and store the gamma/ L in the original packaging!

Protect the packed gamma/ L from moisture and the effects of chemicals!

Environmental conditions for storage and transport:

Storage and transport temperature: -10 bis +50 °C

Humidity: < 92 % relative humidity

Check that the delivery is complete:

- Delivery range*
- Dosing pump with mains lead
  - Operating instructions manual with EU conformity declaration
  - Accessories if applicable

### 4 Device Overview and Control elements

When reading this section it is helpful to fold out the overview “Control elements and key functions”!

#### 4.1 Device overview

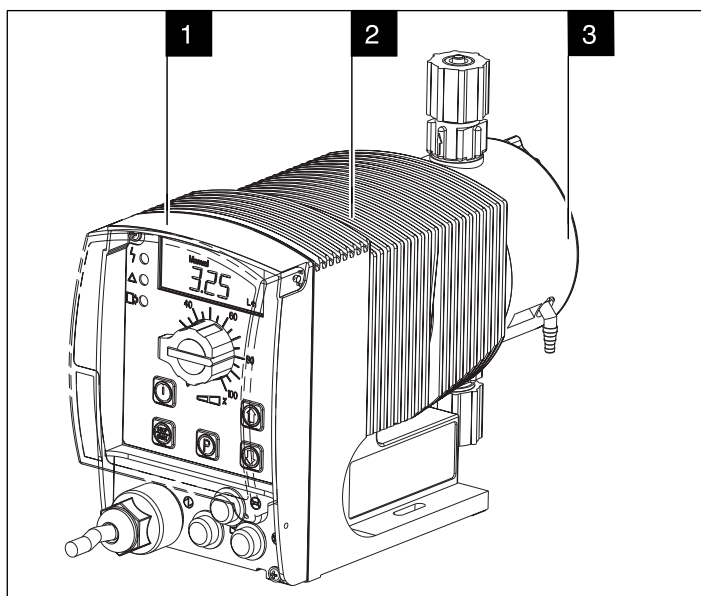

- 1 Control unit
- 2 Power end
- 3 Liquid end

Fig. 01

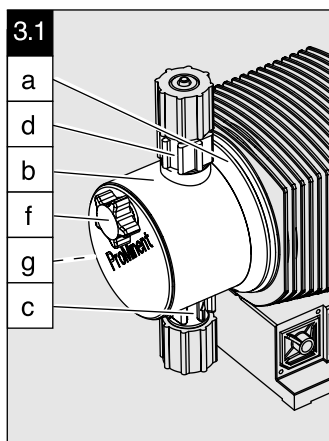

Fig. 02

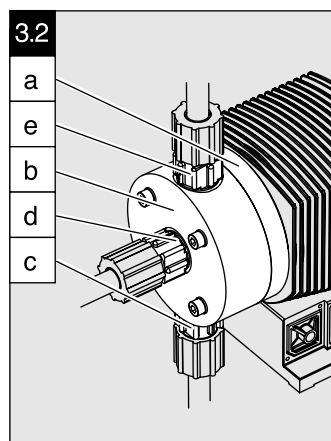

Fig. 03

- a Backplate
- b Liquid end
- c Suction valve
- d Discharge valve
- e Bleed valve
- f Coarse/fine bleed valve
- g Bypass hose nozzle

## 4.2 Control elements

Please acquaint yourself with the gamma/ L control elements with the help of the “control elements and key functions” overview!

*Indicators* The LCD display supports the operation and setting of the gamma/ L with a range of indicators:

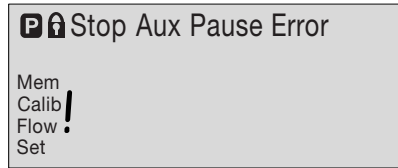

The indicators are interpreted as follows:

|                          |   |
|--------------------------|---|
| <b>Symbol for P key:</b> | The gamma/ L is in settings mode.   |
| <b>Close symbol:</b>     | In a continuous display: lock (if code has been set).<br>In settings mode: indicates access to code menu.   |
| <b>Stop:</b>             | The gamma/ L has been stopped using the STOP/START key.   |
| <b>Aux:</b>              | The gamma/ L is pumping at the auxiliary frequency. In AUX menu: the gamma/ L is in the AUX menu.   |
| <b>Pause:</b>            | The gamma/ L has been stopped using the “pause” function (external).  |
| <b>Error:</b>            | A fault has occurred and the pump has been stopped.   |
| <b>Auto:</b>             | The gamma/ L is in “Auto” operating mode. Depending on the Identcode this means that the gamma/ L can be controlled using PROFIBUS® or the timer (as a comparison see the relevant supplementary instructions).   |
| <b>Mem:</b>              | An additional “memory” function has been set in the “contact” and “batch” operating modes. In CNTCT or BATCH menus (“mem” flashes): the memory function can be set  |
| <b>Calib:</b>            | The gamma/ L is in the CALIB menu.<br>In a continuous display (“calib” flashes): Deviation in stroke length of more than 10 degrees (e.g. a stroke length of 40 % when set at less than 30 % or greater than 50 %) from the value at the time of calibration. |
| <b>Flow:</b>             | The gamma/ L is in the FLOW menu.   |
| <b>Set:</b>              | The gamma/ L is in the SET menu.  |
| <b>Command symbol:</b>   | The number of strokes reached is above the maximum value (99999) that can be shown in the LCD display   |

### NOTE

**The pump gamma/ L only displays the metering output in l or l/h or in gal or gal/h when calibrated.**

## 5 Function Description

|                            |  |
|----------------------------|--|
| <i>Function principle</i>  | Dosing takes place as follows: the dosing diaphragm is forced into the liquid end; the pressure in the liquid end causes the suction valve to close and the chemical flows out of the liquid end through the discharge valve. The dosing diaphragm is then forced back out of the liquid end. The vacuum in the liquid end causes the discharge valve to close and fresh chemical flows into the suction valve in the liquid end. This concludes one operating cycle.<br>The dosing diaphragm is driven by an electronically controlled electrical solenoid. |
| <i>Feed rate</i>           | The feed rate is determined by the stroke length and the stroke rate.<br>The stroke length is set between 0 - 100 % using the stroke length adjusting knob. Optimum dosing reproducibility is achieved by setting the stroke length to between 30 - 100 % (SEK type: 50 - 100 %)!<br>The stroke rate is set using the arrow keys (not in “analogue” operating mode) to between 0 - 180 strokes/min.  |
| <i>Self-bleed function</i> | Pumps with self-bleed function (= SEK types) can operate a prime action even when the discharge tubing is closed, discharging existing air through a bypass valve. These pumps can release gas even during operation, irrespective of the actual operating pressure.<br>An in-built pressure maintenance valve allows accurate dosing even in depressurised states.  |
| <i>Operating modes</i>     | Operating modes are selected using the MODE menu (depending upon identity code, some operating modes may be absent).   |

**“Analog” operating mode: (Identity code, control variant: analogue current)**

The stroke rate is controlled via an analogue electrical signal via the “external control” terminal. Signal processing is pre-selected at the controller.

**“Manual” operating mode: (Identity code, control variant: manual, standard function)**

The stroke rate is controlled manually via the controller.

**“Contact” operating mode:**

**(Identity code, control variant: external 1:1 / external with pulse control)**

This operating mode offers the opportunity to make fine adjustments with small increase/decrease factors. Dosing can be activated by a pulse via the “external control” terminal or by a semiconductor element. With the “pulse control” option it is possible to pre-set a feed quantity (batch) or number of strokes (factor 0.01 to 99.99) via the control unit.

**“Batch” operating function:**

**(Identity code, control variant, external 1:1 / external with pulse control)**

This operating mode offers the option of working with larger transfer factors (up to 65535). Metering can be triggered by pressing the P key or a pulse from the “external control” terminal via a contact or semiconductor element. A batching quantity or number of strokes can be pre-selected via the control unit.

**Operating mode “PROFIBUS®”: (Identcode, control variant: profibus®)**

This operating mode offers the possibility to control the pump via PROFIBUS® (see “supplemental instructions for ProMinent gamma/ L and ProMinent Sigma versions with “PROFIBUS®”).

*Functions* The following functions can be selected using the SET menu:

**“Calibrate” function:**

The gamma/ L can be operated in all operating modes including in calibrating mode. The corresponding continuous displays can show the actual feed quantity or the feed rate. Calibration is maintained within the stroke frequency range 0 - 180 strokes/min. Calibration is also maintained when a stroke frequency is altered up to  $\pm 10\%$ .

**“Pressure level” function:**

It is possible to set different pressure levels.

**“Auxiliary frequency” function:**

It is possible to set a stroke rate in the SET menu, which may be activated via the “external control” terminal. This auxiliary frequency overrides all other pre-set stroke rate frequencies.

**“Flow” function:**

Stops the gamma/ L when the flow is insufficient. In the SET menu, the number of failed strokes is entered after which the pump will be turned off.

The following functions are available as standard:

**“Float switch” function:**

Information on the liquid level in the feed chemical container is transmitted to the gamma/ L. This option requires the installation of a 2-stage float switch. This is connected to the “float switch” terminal.

**“Pause” function:**

The gamma/ L can be stopped by remote control via the “external control” terminal. The “pause” function operates only via the “external control” terminal.

The following functions are activated by keystrokes:

**“Stop” function:**

The gamma/ L can be stopped by pressing the STOP/START key without disconnecting from the mains power supply.

**“Prime” function:**

Priming (short term feed at maximum frequency) is activated by pressing both arrow keys at the same time (in “Stroke rate” permanent display).

*Optional relay* The gamma/ L has two connection options.de deux options :

**“Fault indicating relay” option:**

In the event of fault signals, warning signals or float switch activation signals, connects an electrical circuit to trigger alarm sirens etc. The relay is retrofitted via an aperture in the power end.

**“Fault indicating and pacing relay” option:**

Along with the fault indicating relay, the pacing relay produces a contact for every stroke. The relay is retrofitted via an aperture in the power end.

*Function and error indicators*

The operating and error status is shown via the three LEDs and the “error” indicator on the LCD (see also section 11):

*LCD indicator* If a fault occurs “error” will appear along with an additional fault warning.

*LED indicator*

**Operating indicator (green)**

This indicator is lit as long as the gamma/ L is operating correctly. It stops briefly with each stroke.

**Warning indicator (yellow)**

This warning light appears if the gamma/ L electronics detect a situation that could lead to a fault, e.g. “liquid levels low 1st stage”.

**Warning indicator (red)**

This warning light appears if a fault occurs, e.g. “liquid levels low 2nd stage”.

**Hierarchy of operating modes, functions and fault statuses**

The different operating modes, functions and fault statuses each have a differing effect on whether and how the gamma/ L functions. These effects are given below:

1. Prime
2. Fault, stop, pause
3. Auxiliary frequency
4. Manual, analogue, contact, batch

to:

1. “Prime” can take place in the permanent “Stoke rate” display in any pump mode (as long as it is operational).
2. “Fault”, “stop” and “pause” stop all system parts up to “prime”.
3. The stroke frequency of the “auxiliary frequency” always has precedence over the stroke frequency, which is set by an operating mode listed under 4.

## 6 Assembly and Installation



### WARNING

- Installation must be carried out by a trained engineer!
- Disconnect gamma/ L from mains power supply during installation!
- Risk of electric shock – This pump is supplied with a grounding conductor and grounding-type attachment plug. To reduce the risk of electric shock, be certain that it is connected only to a properly grounding-type receptacle.
- Observe applicable national directives when installing the dosing pumps!
- When connecting with parallel inductive power consumers a switch contact must be fitted, e.g. relay or contactor!



### IMPORTANT

The universal signal cable, the external/connecting cable and the liquid level monitoring cable should never be shortened to less than 1.20 m, otherwise the cable identification system will fail.

*Connection to mains power supply*

Connect the gamma/ L to the mains power supply using the mains lead

*Parallel connection to inductive power consumers*

If the gamma/ L is connected to the mains in parallel with inductive power consumers (e.g. solenoid valve, motor) they must be electrically isolated. This will avoid damage caused by induction and voltage surges when switching off.

- ▶ Fit individual contacts for the gamma/ L and supply power via auxiliary contactor or relay.

If this is not possible, then:

- ▶ Connect a varistor in parallel (order number 710912) or an RC circuit, 0.22  $\mu$ F/220  $\Omega$  (order number 710802).

*Power element (in base of pump)*

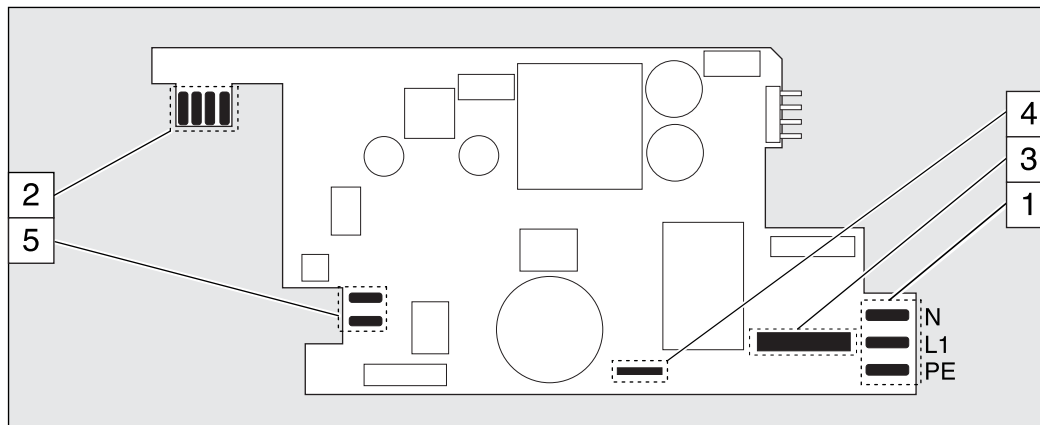

Fig. 04

- 1 Mains terminal
- 2 Relay circuit terminal
- 3 Fuse
- 4 Solenoid earth lead terminal
- 5 Solenoid terminal

*“External control” terminal*

The “external control” terminal is a five pin in-built terminal. It is compatible with the two and four core cables used previously.

The “auxiliary frequency” function is only available with a five core cable.



*gamma/ L configuration*

Electrical interface for “external contact” - “pause” - “auxiliary frequency”:

- tension contacts ouverts : env. 5 V
- Voltage when contacts open: approx. 5 V
- Input resistance: 10 kΩ
- Control: voltage free contact (load: 0.5 mA at 5 V),  
or: Semiconductor switch (residual voltage < 0.7 V)
- Maximum pulse frequency: 25 pulses/s
- Required pulse duration: ≥ 20 ms

Electrical interface for “external analogue”:

- Input load resistance: approx. 120 Ω
- Maximum current at input: 50 mA

*gamma/ L configuration*

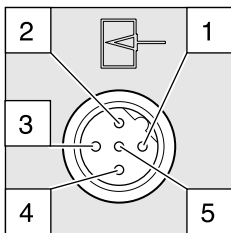

Fig. 05

| Pin   | Function            | 2 core cable    | 4 core cable | 5 core cable |
|-------|---------------------|-----------------|--------------|--------------|
| Pin 1 | Pause               | Jumped at pin 4 | Brown        | Brown        |
| Pin 2 | External contact    | Brown           | White        | White        |
| Pin 3 | External analogue   | –               | Blue         | Blue         |
| Pin 4 | Earth               | White           | Black        | Black        |
| Pin 5 | Auxiliary frequency | –               | –            | Grey         |

*Plug configuration*

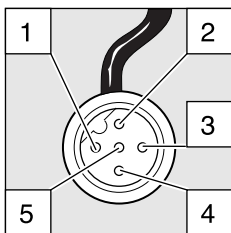

Fig. 06

**“Pause” function**

The gamma/ L is not operating when

- The cable is connected and pins 1 and 4 are free.

The gamma/ L is operating when

- The cable is connected and pins 1 and 4 are connected.
- There is no cable connected (pin 1 is free).

**“Contact” and “Batch” operating modes**

One or more discharge strokes are triggered when pin 2 and pin 4 are connected to one another for at least 20 ms.

Otherwise, pin 1 and pin 4 must be connected.

**“Analogue” operating mode**

The stroke frequency of the gamma/ L is controlled via an electrical signal. The electrical signal is applied between pins 3 and 4.

Otherwise, pin 1 and pin 4 must be connected.

**“Auxiliary frequency” function**

The gamma/ L runs at a pre-set stroke rate when pin 5 and pin 4 are connected to one another. Otherwise, pin 1 and pin 4 must be connected.

The factory setting for this function is 180 strokes.

**NOTE**

**For function and operating mode hierarchy, see section 5!**

**Connecting two gamma/ L pumps in series**

Connect two gamma/ L pumps in series as follows if you wish to control both via **one** electrical signal in the “analog” operating mode (see section 7.4.2):

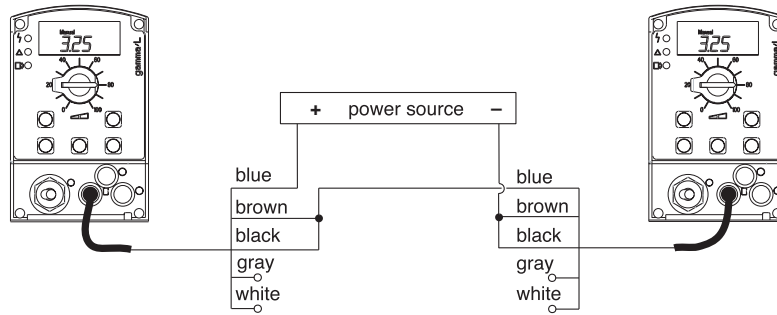

Fig. 07

*“Float switch” terminal* Optional fitting of a 2-stage float switch with prior warning and limit switch capacity.

*gamma/ L configuration*

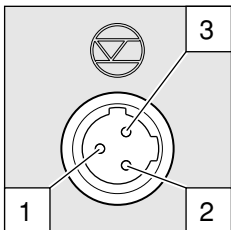

Fig. 08

Electrical interface:

- Voltage when contacts open: approx. +5 V
- Input resistance: 10 kΩ
- Controller: voltage free contact (load: 0.5 mA at + 5V), semiconductor switch (residual voltage < 0.7 V) or:

*Plug configuration*

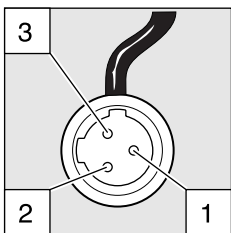

Fig. 09

**Function**

- Pin 1 Earth
- Pin 2 Minimum prior warning
- Pin 3 Minimum limit switch

**3 core cable**

- black
- blue
- brown

*“Dosing monitor” terminal* Optional connection of dosing monitor.

*gamma/ L configuration*

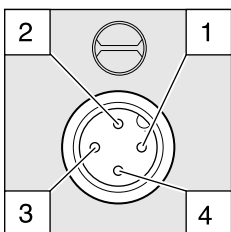

Fig. 10

Electrical interface:

- Voltage when contacts open: approx. +5 V
- Input resistance: 10 kΩ
- Controller: voltage free contact (load: 0.5 mA at +5 V)

*Plug configuration*

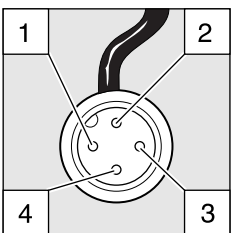

Fig. 11

**Function**

- Pin 1 Power supply (5V)
- Pin 2 Encoding
- Pin 3 Response
- Pin 4 Earth

**4 core cable**

- brown
- white
- blue
- black

**Relay**

“Fault indicating relay”

*output* A fault indicating relay may be ordered optionally. It is used as the signal output when a pump fault has been detected and to indicate the prior warning signal “liquid level low, stage 1” and the fault signal “liquid level low, stage 2”.

Allocation of signal types to “N/O” and “N/C” relay states is selected on the basis of the identity code descriptors.

The relay can be retrofitted and is ready to operate after inserting the relay component (see section 6.2).

The gamma/ L is delivered ex works with default settings for a N/C relay. If an alternative switch function is required the gamma/ L can be reprogrammed at ProMinent.

*Electrical interface*

- Contact load: 250 V/2 A 50/60 Hz
- Operating life: > 200.000 switch cycles

“Fault indicating relay and pacing relay” *output*

A fault indicating relay and pacing relay output may be ordered optionally. The pacing relay output is electrically isolated via an optical coupler with a semiconductor switch. The second switch is a relay as for the “fault indicating relay” variant.

The fault indicating / pacing relay can be retrofitted (see section 6.2).

The gamma/ L is delivered ex works with default settings for a N/C fault indicating relay and a N/O pacing relay. If an alternative switch function is required the gamma/ L can be reprogrammed at ProMinent.

*Electrical interface*

**For semiconductor switch**

- Residual voltage: < 0,4 Volt at  $I_c = 1 \text{ mA}$
- Maximum voltage: < 100 mA
- Maximum current: 24 V/DC
- Pacing relay pulse duration: approx. 100 ms

**For relay output**

- Contact load: 24 V/100 mA 50/60 Hz
- Operating life: > 200.000 switch cycles

**Relay cable contact configuration**

“Fault indicating relay” *option*

| VDE cable | CSA cable | Contact              |
|-----------|-----------|----------------------|
| white     | white     | NO (normally open)   |
| green     | red       | NC (normally closed) |
| brown     | black     | C (common)           |

“Fault indicating relay and pacing relay” *option*

| VDE cable                 | Contact                | Relay |
|---------------------------|------------------------|-------|
| yellow NO (normally open) | Fault indicating relay |       |
| green C (common)          | Fault indicating relay |       |
| white NO (normally open)  | Pacing relay           |       |
| brown C (common)          | Pacing relay           |       |

**6.1 Retrofitting relays**

**Delivery range:**

- 1 relay circuit set with 2 screw fasteners
- 1 relay cable set with socket
- 1 seal

*Press-out relay opening*



**WARNING**

Disconnect gamma/ L from the mains power supply and rinse liquid end before commencing work (see section 12)!



**IMPORTANT**

When preparing the opening, ensure that the punch is not forced through the entire pump base!  
Pump circuits may become damaged.

- ▶ Place the gamma/ L on a firm surface with the relay opening press-out section at the top (see fig. 12:a)
- ▶ Place a punch (dia. 8-15 mm) in the centre of the relay opening press-out section, and strike briefly and sharply with a hammer (approx. 250 g)
- ▶ If necessary clean up the edges of the opening
- ▶ Remove the pressed out section from the gamma/ L

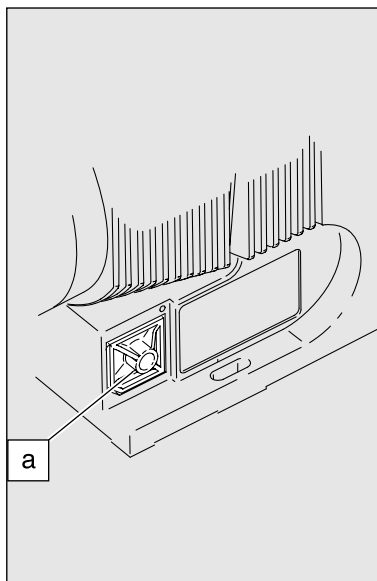

Fig. 12

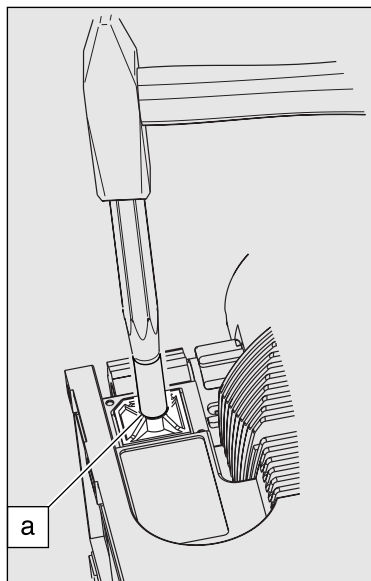

Fig. 13

- Inserting the relay component*
- ▶ Hold the relay component with your right hand gripping the left and right hand edges of the relay cover, and tilt the front end slightly to the left (see fig. 14)
  - ▶ Push the relay component through the relay opening, holding the upper corner of the lower edge against the guide rail on the pump base, until the contact of the relay component has reached the controller contact. (See fig. 15: test: can you still move the end of the circuit back and forth?)
  - ▶ Gently push the relay component right into the opening.
  - ▶ Screw the relay cover firmly onto the housing using the screws provided.
  - ▶ Insert the relay cable plug seal into the relay cover and screw on the plug (see fig. 16)
- The gamma/ L is delivered ex works with default settings for a N/C fault indicating relay and a N/O pacing relay. If an alternative switch function is required the gamma/ L can be reprogrammed at ProMinent.

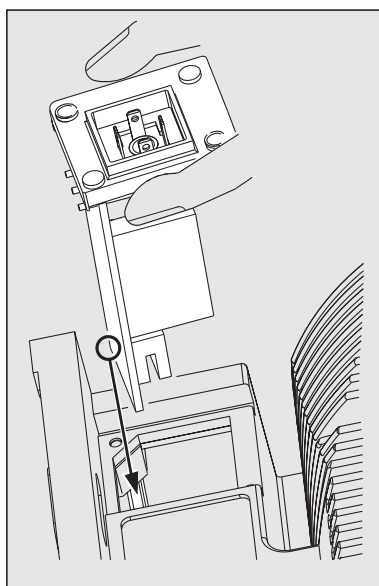

Fig. 14

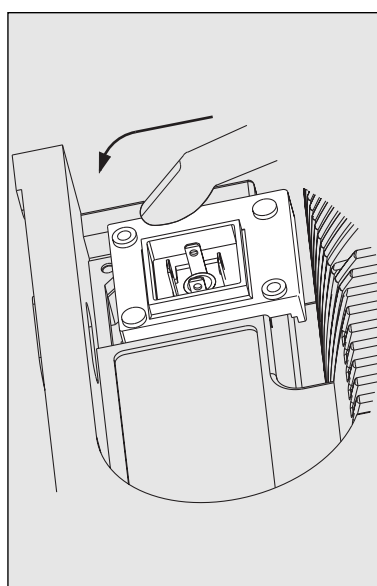

Fig. 15

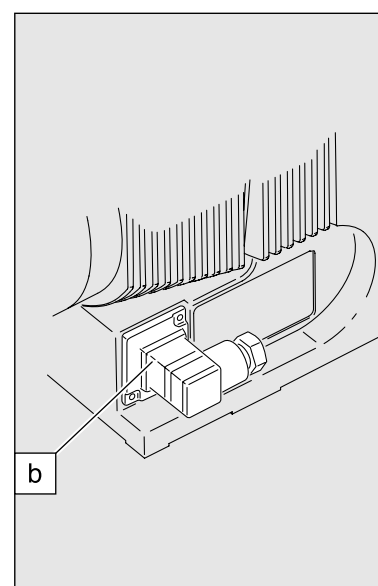

Fig. 16

## 7 Settings

### NOTE

- Open out the fold-out page following the title page fully! There you will find the overviews “control elements and key functions” and “operating/settings diagram”.
- If no keys are pressed within a period of 1 minute, the gamma/ L will return to a continuous display.

### Basic information for setting up the gamma/ L

 = possibilité de réglage

 = clignote

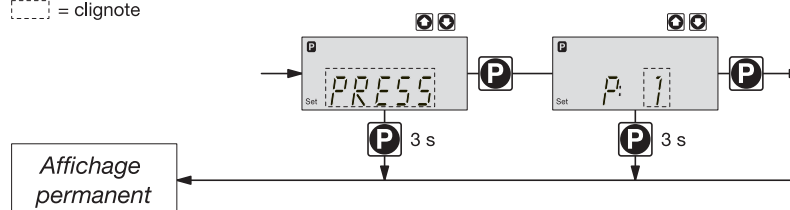

**Confirm entries** Press the P key briefly;  
you will automatically move to the next menu option or to a continuous display.

**Exit menu option without confirming** Press the P key for 3 s:  
The entry is cancelled and you will return to a continuous display.

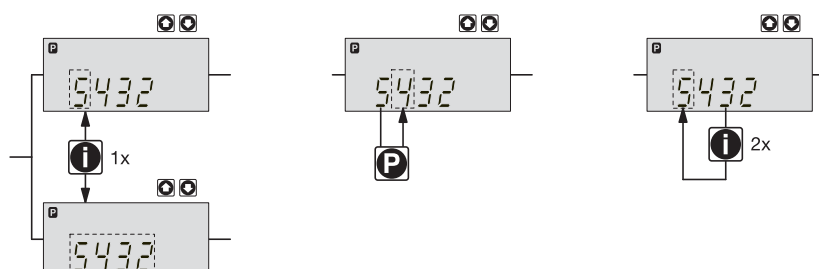

**Incremental change of a value** Press the i key 1x;  
you can toggle between altering the digits of a value (“change individual digits” = standard) or incremental alteration of a value (“change a figure”).

**Change adjustable values** Press UP or DOWN arrow key;  
The flashing digit or figure will start to increase or decrease incrementally.

**Confirm adjustable values** For “change individual digits”: confirm each digit using the P key. When the last digit has been confirmed you will automatically move to the next menu option or to a continuous display.  
For “change a figure”; press the P key 1x; you will simultaneously move to the next menu option or to a continuous display.

**Correct wrongly set digits** Press the i key 2x;  
you will go back to the first digit.

## 7.1 Check adjustable values

Before setting up the gamma/ L you can check the current settings of adjustable values.

Press the i key (“i” as in “info”) when the gamma/ L is in continuous display mode  
(There is no P key symbol in the LCD display):

Each time you press the i key you will see a different continuous display. The number of continuous displays depends upon the identcode, the selected operating mode and the connected accessories (see overview “continuous displays”).

## 7.2 Change to settings mode

If you hold down the P key for 2 seconds in any continuous display, the gamma/ L will change to the settings mode.

If CODE 1 is set, the code must be entered after pressing the P key.

The following menu options appear first in the settings mode (see also overview “operating/ settings diagram”):

- MODE menu
- CODE menu (optional)
- SET menu
- CLEAR window

In order to adapt the gamma/ L to your process requirements you must:

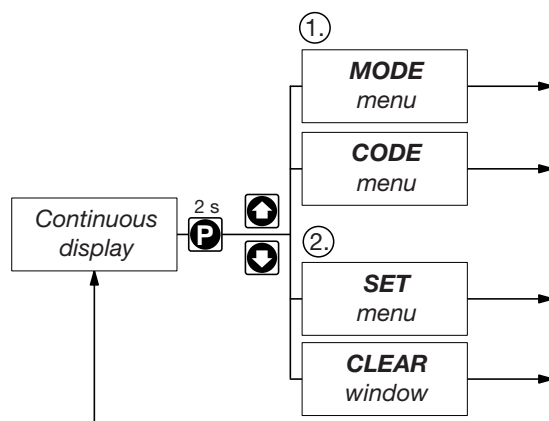

1. Select the operating mode in the MODE menu
2. Adjust settings to this operating mode in the SET menu

### 7.3 Select operating mode (MODE menu)

The following operating modes are selected via the MODE menu (depending upon identcode, some operating modes may be absent):

- Manual: for operation by hand  
(Identcode, control variant: manual, standard option)
- Analogue: for electronic control  
(Identcode, control variant: analogue current)
- Contact: for contact operation  
(Identcode, control variant: external 1:1 / external with pulse control)
- Batch: for batch operation  
(Identcode, control variant: external with pulse control)

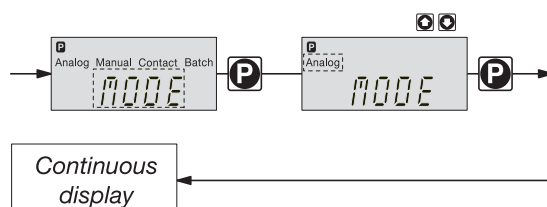

### 7.4 Settings for operating mode (SET menu)

In the SET menu you can adjust various settings depending upon the selected operating mode.

The following programmable function settings menus appear in all operating modes:

- Calibrate (CALIB menu)
- Pressure levels (PRESS menu)
- Auxiliary frequency (AUX menu)
- Flow (FLOW menu, available only if flow monitor is connected)

See also section 7.5!

Further settings menus depend upon the selected operating mode.

#### 7.4.1 Settings for “manual” operating mode

There are no other settings menus in the overall SET menu for the “manual” operating mode apart from those described in 7.5.

#### 7.4.2 Settings for “analogue” operating mode (ANALG menu)

In addition to those settings menus described in 7.5, there is an additional ANALG menu in the overall SET menu for the “analogue” operating mode.

The stroke rate is controlled by an analogue electrical signal via the “external control” terminal. You can select three signal-processing methods:

- 0 - 20 mA: at 0 mA the gamma/ L does not operate  
at 20 mA the gamma/ L operates at max. stroke rate  
Between these two extremes the stroke rate is proportional to the electrical signal.

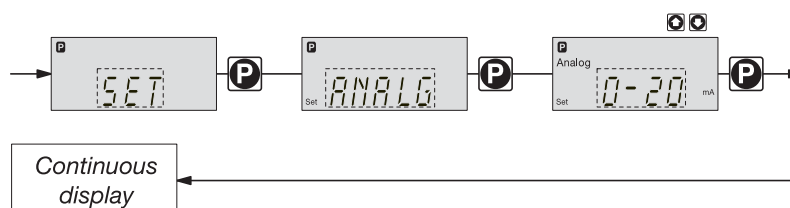

- 4 - 20 mA: at 4 mA the gamma/ L does not operate  
at 20 mA the gamma/ L operates at max. stroke rate  
Between these two extremes the stroke rate is proportional to the electrical signal.  
For signals of below 3.8 mA a fault will be detected and the gamma/ L will stop (e.g. cable break).
- Curve: In the “curve” processing mode you can programme the gamma/ L ratios. There are 3 options available:
  - - - - - = straight line
  - - - - - = lower band
  - - - - - = upper band

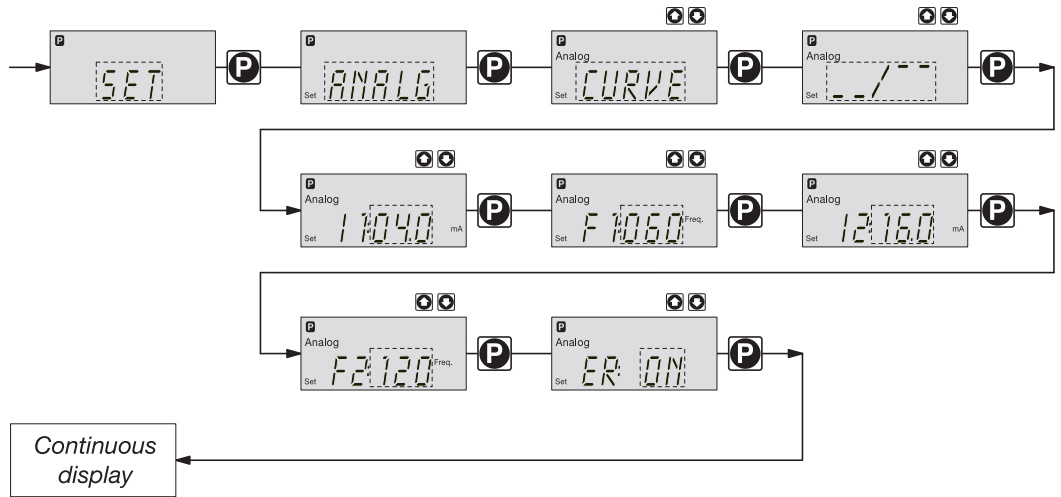

**Straight line:**

The following symbol appears in the LCD display: - - - - .  
You can enter any stroke frequency ratio for the gamma/ L in proportion to the electrical signal. You must enter two points P1 (I1, F1) and P2 (I2, F2). F1 is the stroke rate at which the pump should operate at current I1: the straight line and the ratio are fixed accordingly:

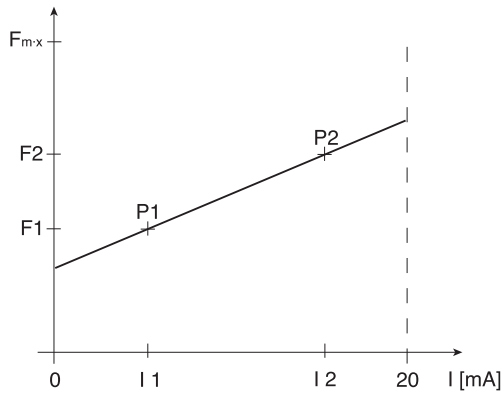

Fig. 17

**NOTE**

Draw a diagram like the one above - with values for (I1, F1) and (I2, F2) - in order to set the gamma/ L to your required stroke rate!



**Lower/upper band:**

This processing mode allows you to control a pump via an electrical signal as shown in the diagrams below.

You may also control two pumps for different feed chemicals from a single signal (e.g. one acid pump and one alkali pump from a pH sensor signal). The pumps must be connected electrically in series (see wiring plan in section 6.1).

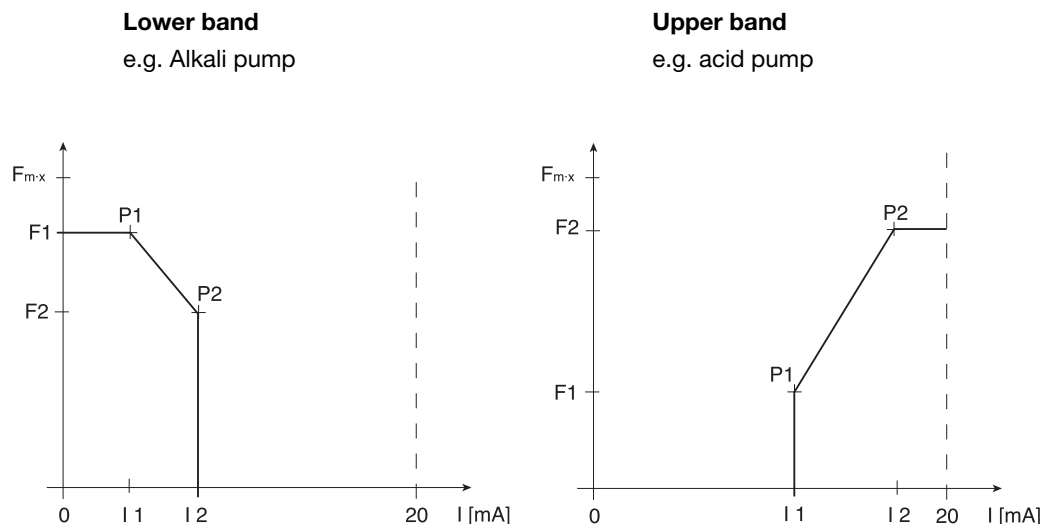

Fig. 18

Fig. 19

**Lower band:**

The symbol  $\overline{\_}$  appears in the LCD display. The gamma/ L will operate below  $I_1$  at  $F_1$ . Above  $I_2$ , the gamma/ L ceases to operate. Between  $I_1$  and  $I_2$  the stroke rate is between  $F_1$  and  $F_2$ , proportional to the signal current.

**Upper band:**

The signal  $\_/\overline{\_}$  appears in the LCD display. The gamma/ L will cease to operate below  $I_1$ . Above  $I_2$ , the gamma/ L will operate at  $F_2$ . Between  $I_1$  and  $I_2$  the stroke rate between is  $F_1$  and  $F_2$ , proportional to the signal current.

The smallest processable difference between  $I_1$  and  $I_2$  is 4 mA.

*Error processing* In the "ER" (error) menu option you can activate an error processing function for the "curve" mode. An error message appears for signals below 3.8 mA and the gamma/ L stops.

**7.4.3 Settings for "contact" operating mode (CONTCT menu)**

In addition to those settings menus described in 7.5, there is an additional CONTCT in the overall SET menu for the "contact" operating mode.

The operating mode "contact" allows you to activate a single stroke or a series of strokes. The strokes can be activated by a pulse or via the "external control" terminal. This operating mode is intended to transfer input pulses into a reduction (break) or small increase in strokes.

**IMPORTANT**

**When switching to another operating mode the factor is reset to "1".**

**The following versions are available:**

- Contact - identcode: external 1:1
- Contact - identcode: external with pulse control

**Contact – identcode: external 1:1**

In the “contact - identcode: external 1:1” version the gamma/ L makes precisely 1 stroke per pulse (identcode: external 1:1).

No entry possible.

**Contact – identcode: external with pulse control**

In the “contact - identcode: external with external pulse control” you can enter the number of pulses after which a stroke should be carried out. “Contact - identcode: external with external pulse control” is intended for small dosing quantities.

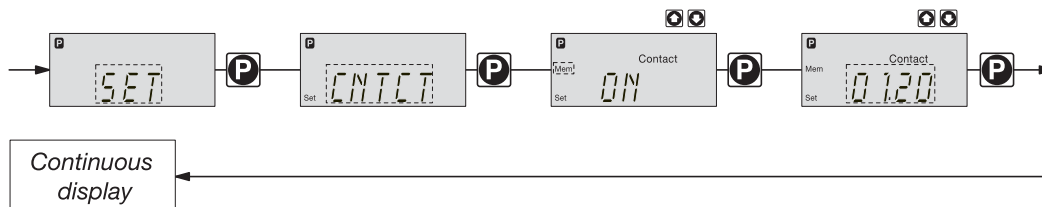

The number of strokes per pulse depends upon the factor, which you can enter. This allows you to vary to a certain extent the input pulses by a factor of 1.01 to 99.99 and/or reduce by a factor of 0.01 to 0.99:

“Number of strokes activated = factor x number of input pulses”

| Examples         | Factor | Pulse (sequential) | Stroke number (sequential) |
|------------------|--------|--------------------|----------------------------|
| <b>Increase</b>  | 1      | 1                  | 1                          |
|                  | 2      | 1                  | 2                          |
|                  | 25     | 1                  | 25                         |
|                  | 99.99  | 1                  | 99.99                      |
|                  | 1.50   | 1                  | 1.5 (1 / 2)                |
|                  | 1.25   | 1                  | 1.25 (1 / 1 / 1 / 2)       |
| <b>Reduction</b> | 1      | 1                  | 1                          |
|                  | 0.50   | 2                  | 1                          |
|                  | 0.10   | 10                 | 1                          |
|                  | 0.01   | 100                | 1                          |
|                  | 0.25   | 4                  | 1                          |
|                  | 0.40   | 2.5 (3 / 2)        | (1 / 1)                    |
|                  | 0.75   | 1.33 (2 / 1 / 1)   | (1 / 1 / 1)                |

*Explanation of increase*

|                   |   |
|-------------------|---|
| At a factor of 1  | For every 1 pulse, 1 stroke is activated    |
| At a factor of 2  | For every 1 pulse, 2 strokes are activated  |
| At a factor of 25 | For every 1 pulse, 25 strokes are activated |

*Explanation of decrease*

|                     |   |
|---------------------|---|
| At a factor of 1    | After 1 pulse, 1 stroke is activated  |
| At a factor of 0.5  | After 2 pulses, 1 stroke is activated   |
| At a factor of 0.1  | After 10 pulses, 1 stroke is activated  |
| At a factor of 0.75 | After 2 pulses, 1 stroke is activated, then after 1 pulse, 1 stroke is activated, then after 2 pulses, 1 stroke is activated etc. |

**NOTE**

If a remainder occurs when the factor is processed, the gamma/ L counts up the remainder values. When the sum reaches or exceeds “1” the gamma/ L will activate a stroke. This ensures that the stroke number corresponds exactly to the factor throughout the dosing operation.

The number of input pulses which have not been processed are stored by the gamma/ L in the stroke memory. When the STOP/START key is pressed or the “pause” function is activated, the stroke memory is deleted (this can be avoided using the “memory” extension function, see below).

The “contact - identcode: external with pulse control” version allows optimum adaptation of the gamma/ L, in conjunction with e.g. water contact meters, to any process.

**“Memory” extension function**

The “memory” extension function can be optionally activated (“mem” appears in the LCD display). When “Memory” is activated, the gamma/ L adds up the unused excess strokes, up to the stroke memory’s maximum capacity of 65535 strokes. If the maximum capacity is exceeded the pump will malfunction.

**7.4.4 Settings for “batch” operating mode (BATCH menu)**

In addition to those settings menus described in 7.5, there is an additional BATCH menu in the overall SET menu for the “batch” operating mode.

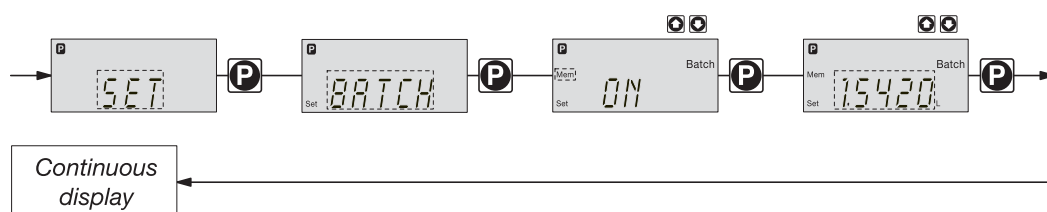

The “batch” operating mode is a variant of the “contact” operating mode (see 7.4.3).

You can pre-select a stroke number (no breaks, whole numbers only from 1 to 65535) as well as a feed quantity (batch). To switch between entries for “stroke number” and “feed quantity” press the i key 1x in the corresponding menu option (see also overview “operating/settings diagram”, fold-out page).

The “batch” operating mode is intended for large dosing quantities.

Metering is activated by pressing the P key or via a pulse from the “external control” terminal.

The number of input pulses which have not been processed are stored by the gamma/ L in the stroke memory. The stroke memory is limited to the batch size if “Memory” is not activated (with “Memory” this is 65535 strokes). You can clear it by changing to a different operating mode.

**“Memory” extension function**

The “memory” extension function can be optionally activated (“mem” appears in the LCD display). When “Memory” is activated, the gamma/ L adds up the unused excess strokes, up to the stroke memory’s maximum capacity of 65535 strokes. If the maximum capacity is exceeded the pump will malfunction.

## 7.5 Settings for programmable functions (SET menu)

The following programmable function settings menus appear in all operating modes:

- Calibrate (CALIB menu)
- Pressure levels (PRESS menu)
- Auxiliary frequency (AUX menu)
- Flow (FLOW menu, available only if flow monitor is connected)

### 7.5.1 Settings for “calibration” function (CALIB menu)

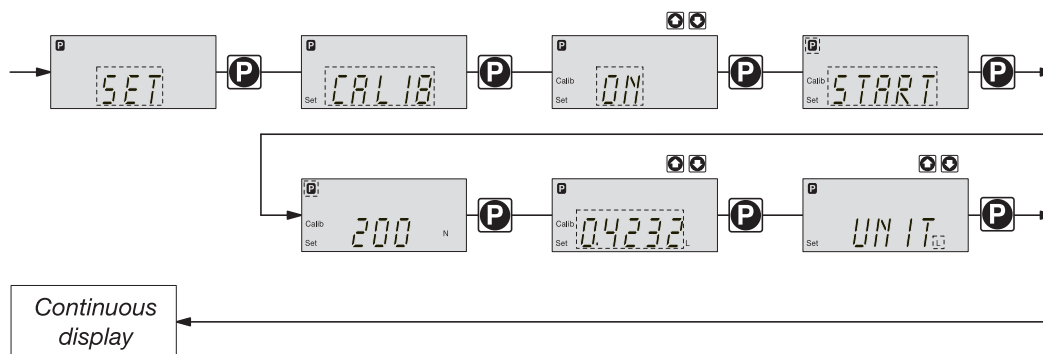

The gamma/ L can also run in calibration mode. The corresponding continuous displays show the current dosing quantities or the feed rate.

Calibration is maintained when a stroke rate is altered up to  $\pm 10$  degrees (where the stroke length is set at 40 %, the range is 30-50 %). If the stroke rate is altered more than  $\pm 10$  degrees the yellow warning light is lit, the continuous display flashes and the flashing message “calib” appears.

#### NOTE

- **Do not go below 30 % stroke length (SEK type: 50 %). This will significantly affect accuracy of calibration.**
- **Calibration becomes increasingly accurate the more strokes made by the gamma/ L during calibration (recommended: at least 200 strokes).**



#### WARNING

**If using a hazardous feed chemical, the following setting instructions ensure adequate safety precautions have been taken!**

- Calibration*
- ▶ Insert the suction tube into a measuring cylinder containing the feed chemical - the discharge tubing must also be correctly installed (operating pressure, ...!)
  - ▶ Suck up the feed chemical (press both arrow keys at the same time) when the suction tube is empty
  - ▶ Note the liquid level in the measuring cylinder and the stroke length
  - ▶ Select the CALIB menu and go to the first menu option using the P key
  - ▶ Select “ON” using an arrow key and change to the next menu option using the P key
  - ▶ To commence calibration, press the P key. The gamma/ L starts to pump and displays the number of strokes (“STOP” appears at regular intervals) (the gamma/ L works at the stroke frequency set under “MANUAL“).
  - ▶ After a sufficient number of strokes, stop the gamma/ L with the P key
  - ▶ Calculate the dosed quantity (difference between the original quantity and the quantity remaining)
  - ▶ Enter this quantity in the next menu and then go to the next menu option using the P key
  - ▶ Select the unit (“L” or “gal”) in the “UNIT” menu with an arrow key

The gamma/ L is calibrated.

The corresponding continuous displays show the calibrated values.

The total stroke number and total litres are set during calibration to “0”.

The gamma/ L is in the STOP state.

### 7.5.2 Settings for the “pressure levels” function (PRESS menu)

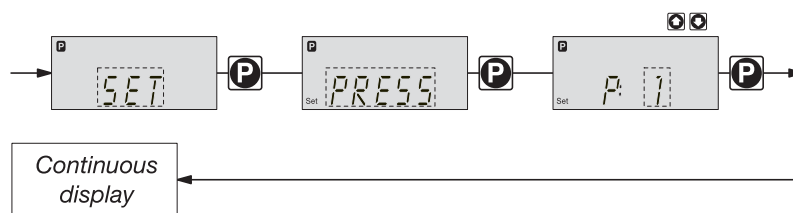

The programmable function “pressure levels” is used to reduce the rated pressure of the gamma/ L.



#### CAUTION

- The rated pressure can be considerably exceeded at stroke lengths of below 100 %! The rated pressure relates to a stroke length of 100 %.
- If another liquid end size is installed the pump must be reprogrammed on factory premises!
- Select as large a rated pressure as required and as small as possible! This will increase system safety (reduces the risk of the tubing bursting when blocked)! This also protects the diaphragm and saves electricity.

#### NOTE

If installing another liquid end size the pump must be reprogrammed on factory premises.

The following rated pressures can be selected for these liquid end sizes (rated pressure in bar):

| Liquid end size  | Pressure level 1 | Pressure level 2 | Pressure level 3 | Pressure level 4 |
|------------------|------------------|------------------|------------------|------------------|
| 1601, 1602, 1605 | 4                | 7                | 10               | 16               |
| 1000, 1005, 1008 | 4                | 7                | 10               |                  |
| 0708, 0713       | 4                | 7                |                  |                  |

No adjustments can be made for pump types 0413, 0420, 0220, 0232.

### 7.5.3 Settings for “auxiliary frequency” function (AUX menu)

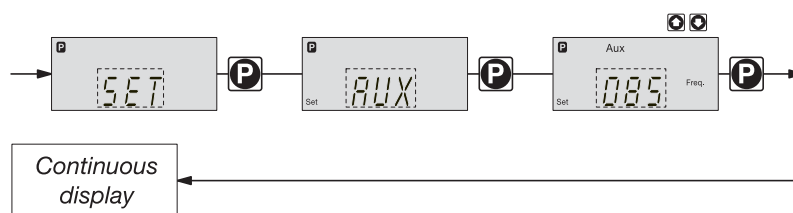

The programmable function “auxiliary frequency” allows switching to a different stroke frequency, which can be set in the AUX menu. It can be activated via the “external control” terminal. When the auxiliary frequency is activated, “aux” appears in the LCD display.

This auxiliary frequency overrides the current stroke frequency set for the selected operating mode.

### 7.5.4 Settings for the “flow” function (FLOW menu)

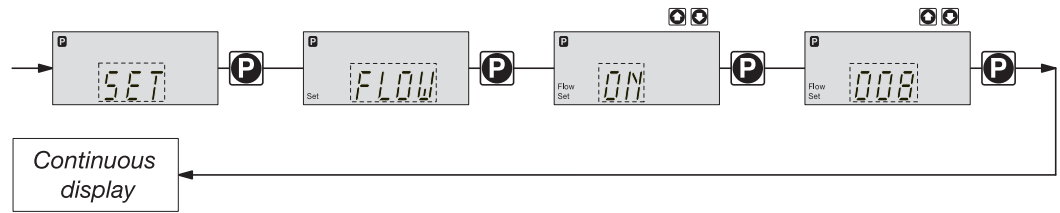

The flow menu only appears when a dosing monitor is connected to the “dosing monitor” terminal. This dosing monitor registers each discharge stroke of the gamma/ L at the discharge connector and transmits it back to the gamma/ L. If this response transmission is serially omitted for a period set in the FLOW menu (due to failure or below-minimum dosing) the gamma/ L stops.

### 7.6 Setting code (CODE menu)

The code menu is used to select whether you want to prevent access to parts of the settings options.

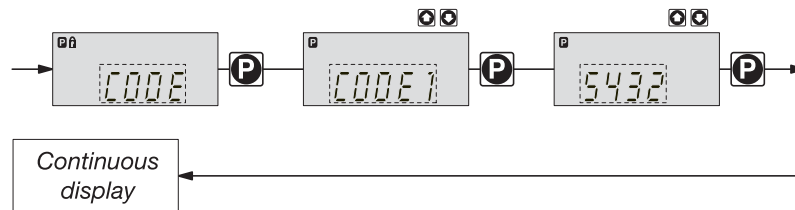

In the first menu option you can choose CODE 1 or CODE 2 (both use the same number).

- Select CODE 1 to prevent access to the settings mode (① in the overview “operating/ settings diagram”, fold-out page). In the next menu option, enter the number you wish to use as the code.
- Select CODE 2 to prevent access to the settings options for directly alterable values in the continuous displays (② in the overview “operating/settings diagram”, fold-out page). In the next menu option, enter the number you wish to use as the code.
- Select NONE to remove a pre-set security lock.

### 7.7 Cancel total stroke number or total litres (CLEAR window)

In the CLEAR window you can delete the stored total stroke number and simultaneously the total litres (= set to “0”). You may then press the P key briefly to exit this window.

The values displayed are counted incrementally from the point of commissioning the pump, or from the last delete action.

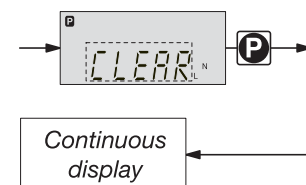

## 8 Operating

This section describes all operating options available to you when the gamma/ L is in continuous display mode (no P key symbol in the LCD display).

### NOTE

- **Open out the fold-out page following the title page fully! There you will find the overviews “control elements and key functions” and “operating/settings diagram”.**
- **Look at the overview “continuous displays”. This page shows you which displays are available in which operating mode, and which values are directly alterable in the corresponding continuous displays.**

### 8.1 Manual operation

- Set stroke length* Stroke length is continually adjustable within a range of 0 - 100 %. The recommended stroke length range, which will practically guarantee technical reproducibility, is 30 - 100 % (SEK type: 50 - 100 %).
- The following operating options are available via the different keys (see also figure on the next page):
- Stop/Start gamma/ L* To stop gamma/ L: press STOP/START key.  
To start gamma/ L: press STOP/START key.
- Start batch* Press the P key briefly in “batch” operating mode.
- Load factory settings* Press the P key for 15 s only if you wish to load factory calibration settings! Current settings will be deleted.
- Change to settings mode* When you press the P key for 2 s in any continuous display the gamma/ L will change to settings mode (see section 7).  
If CODE 1 is set, the code must be entered after pressing the P key.
- Check adjustable values* Each time you press the i key you will see a different continuous display. The number of continuous displays depends upon the identity code, the selected operating mode and the connected accessories.
- Change directly alterable values* To change a value (see below) directly in the corresponding continuous display, press one of the arrow keys until “set” appears in the LCD display. The delay has been programmed in to prevent inadvertent changing of values.  
If CODE 2 has been set, this code must be entered after pressing the arrow key.
- Directly alterable values are as follows:
- Stroke rate* In “manual”, “contact” and “batch” operating modes:  
The stroke rate can be altered in the “stroke rate” display.
- Feed rate* In “manual” operating mode  
The feed rate can be altered in the “feed rate” display.
- Factor* The factor is the number of strokes activated by an external pulse or a press of the P key (in “batch” mode only).  
In “batch” operating mode:  
You can alter the factor from the “remaining strokes” display.  
The gamma/ L returns to the original continuous display a few seconds after the factor has been reset.
- Batch size* In “batch” operating mode:  
The batch size can be changed from the “batch size/remaining litres” display.  
The gamma/ L returns to the original continuous display a few seconds after the batch size has been reset.
- Priming* The “priming” function is activated by pressing both arrow keys at the same time in “Stroke rate” permanent display.

*Cancel error* Error messages are cancelled by pressing the P key briefly.

*Display programme versions*

Press on the P key for 10 seconds to display the programme versions.

Example: "V 1052" + X 1010".

Release the key on "LOAD 3" immediately.

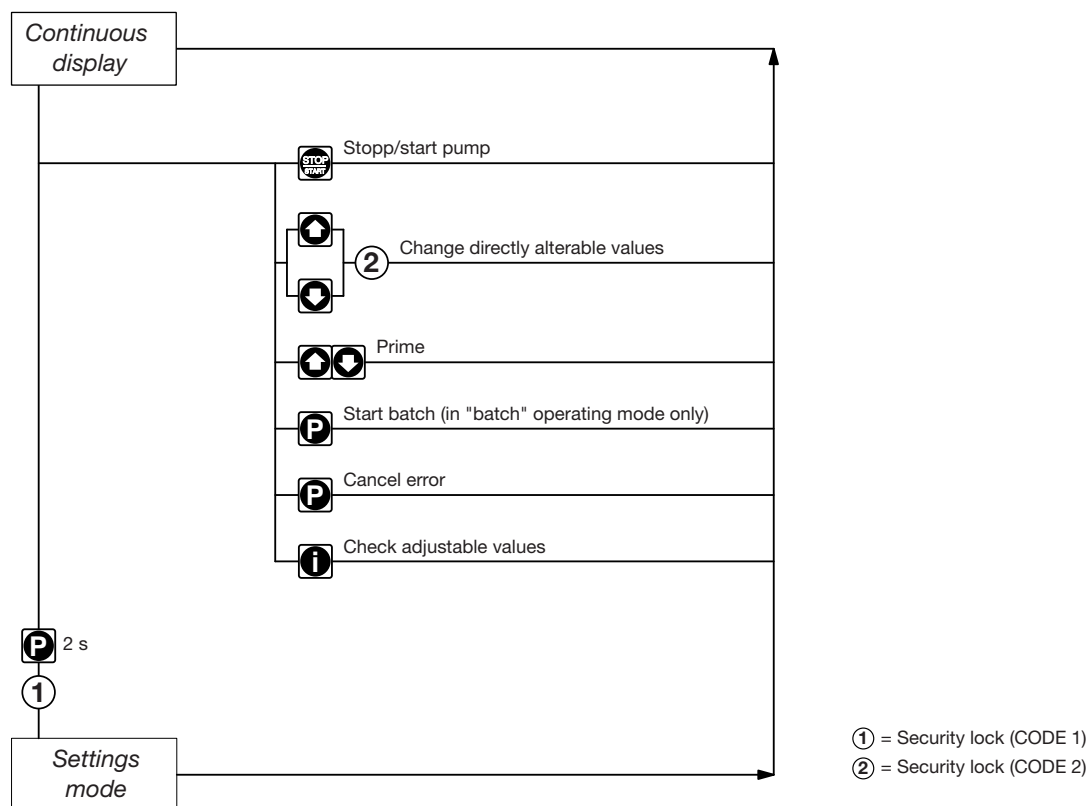

## 8.2 Remote control

It is possible to control the gamma/ L remotely via a signal cable or Profibus® (see section 6.1 and section 7, "Supplementary Instructions for ProMinent® gamma/ L and ProMinent® Sigma versions with Profibus®" and plant documentation).



## 9 Maintenance

- Maintenance intervals*
- Every quarter, when subject to normal usage (continuous operation - approx. 30 % )
  - Shorter intervals when subject to heavier usage (e.g. continuous operation)

*Maintenance actions* Standard liquid ends:

- ▶ Check the diaphragm for damage (see section 10)
- ▶ Check chemical seepage at vent hole
- ▶ Check that the discharge tubing is connected firmly to the liquid end
- ▶ Check that discharge and suction valves are firmly fixed
- ▶ Check that the liquid end is generally watertight (especially vent hole! See fig. 20)
- ▶ Check for correct feed: run the gamma/ L run for a short period (press both arrow keys together)
- ▶ Check electrical connections for wear
- ▶ Check that liquid end screws are fastened tightly (on coarse/fine bleeding versions, first remove knob and cover)

Screw fastening torque: 4,5 to 5 Nm

### NOTE

- For PP liquid end, check fastening torque every quarter!

Additionally, for liquid ends with coarse/fine bleed function and SEK type:

- Check that the bypass tubing is connected firmly to the liquid end
- Check that the bleed valve is firmly fixed in place
- Examine the discharge and bypass tubing for kinks
- Check that the coarse/fine bleed function is working correctly

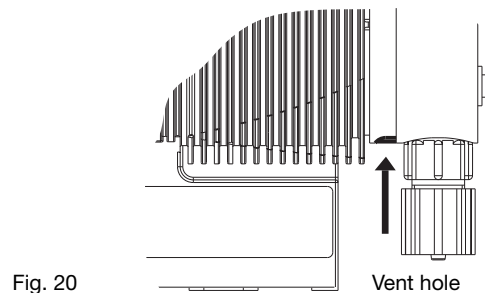

Fig. 20

## 10 Repairs

### NOTE

Repair work may be carried out by authorised personnel only, or on factory premises:

- Replacement of damaged mains cables
- Replacement of fuses and electronic controller.

Please contact your nearest ProMinent branch or representative!

When sending the pump for repair make sure it is clean and that the liquid end has been thoroughly rinsed out (see section 12)! If, despite careful emptying and cleaning, safety precautions are still required for handling the gamma/ L, the necessary information must be entered in the safety declaration!

The safety declaration is a component of the inspection/repair order.

An inspection or repair can only be carried out when a safety declaration has been correctly and completely filled out by an authorised and qualified member of staff from the company operating the pump.

A form is included in the appendix.



### **WARNING**

**Pumps used for radioactive materials cannot be returned to ProMinent after use!  
They will not be accepted by ProMinent!**

Repairs: These should only be carried out by qualified personnel  
(in accordance with Safety section):

- Cleaning the valve
- Changing the diaphragm



### **WARNING**

- **Always take suitable precautions when using hazardous chemicals!**
- **Ensure equipment is de-pressurised**

### **NOTE**

**Take the explosion drawings annexed to the help.**

*Cleaning the discharge valve (PP, NP) for types 1000, 1005, 1605, 1601, 1602*

### **NOTE**

- **Discharge and suction valves are different! Dismantle one after the other to avoid confusion.**
- **Only use new parts, which fit your valve (in shape and chemical resistance)!**
- **The pump must be reset after replacing a valve.**
- **Insert an Allen key or similar into the smaller hole of the pressure connector and push out the valve inserts.**

*Cleaning the suction valve (PP, NP) for types 1000, 1005, 1605, 1601, 1602*

Dismantling, cleaning and reassembly of the suction valve is practically the same as for a discharge valve.

Notice however that:

- both valve inserts are actually identical
- an additional spacer is found under the valve inserts
- in the liquid end a shaped seal is used instead of an O-ring
- the flow direction of the suction connection is reversed as for the pressure connector.

*Cleaning the discharge valve (PP, NP) for types 0708, 1008, 0220, 0420, 0413, 0713, 0232*

### **NOTE**

- **Discharge and suction valves are different! Dismantle one after the other to avoid confusion!**
- **Only use new parts, which fit your valve (in shape and chemical resistance)!**
- **The pump must be reset after replacing a valve.**
- **Insert an Allen key or similar into the smaller hole of the pressure connector and push out the valve inserts.**

*Cleaning the suction valve (PP, NP) for types 0708, 1008, 0220, 0420, 0413, 0713, 0232*

Dismantling, cleaning and reassembly of the suction valve is practically the same as for a discharge valve.

Notice however that:

- an additional spacer is found under the valve inserts
- in the liquid end the O-ring is used, not the shaped seal
- the flow direction of the suction connection is reversed as for the pressure connector.

## Change diaphragm

**WARNING**

- **Always take suitable precautions when using hazardous chemicals!**
- **Ensure that the equipment is de-pressurised!**

- ▶ Empty the liquid end (turn the unit upside down and let the feed chemical run out, rinse with a suitable material: rinse the liquid end thoroughly after use with hazardous materials!).
- ▶ When gamma/ L is running set the stroke length to 0 % (the drive axis is then set).
- ▶ Switch off the gamma/ L.
- ▶ Unscrew the hydraulic connectors from the discharge and suction side.
- ▶ For versions with coarse/fine bleed function: firstly pull out the coarse/fine bleed (knob), then lift off the cover from the liquid end using a screwdriver.
- ▶ Remove the screws (1).

For pump types 0220, 0232 and 0420 see the following page (4 holes on the diaphragm rim)!

Supply unit types,  
except 0220, 0232  
and 0420

- ▶ Loosen the liquid end (2) and the top plate (4) from the pump housing (6) (loosen only!).
- ▶ Hold the housing (6) in one hand and with the other, clamp the diaphragm (3) between the liquid end (2) and the top plate (4); release the diaphragm (3) from the drive spindle with a light anticlockwise turn of the liquid end (2) and top plate (4).
- ▶ Unscrew the diaphragm (3) completely from the drive spindle.
- ▶ Remove the top plate (4) from the housing (6).
- ▶ Check the condition of the safety diaphragm (5) and replace if necessary.
- ▶ Push the safety diaphragm (5) only as far onto the drive axis until it lies flat on the pump housing (6) – no further!
- ▶ Screw the new diaphragm (3) carefully up to the stop on the drive axis – this must be exact to ensure correct metering!
- ▶ Screw the diaphragm (3) tight once more.
- ▶ Position the top plate (4) on the pump housing (6).

**IMPORTANT**

- **The leakage hole must point downwards when the pump is fully assembled (see fig. 20).**
- **Position the top plate (4) correctly on the pump housing (6). Do not distort the top plate on the pump housing, otherwise the safety diaphragm (5) will not fit.**

- ▶ Lay the diaphragm (3) into the top plate (4).
- ▶ Hold the top plate (4) and screw the diaphragm (3) in a clockwise direction until it is firmly in position (you will feel the resistance of the return spring).

**IMPORTANT**

- **Do not overtighten the diaphragm (3) (particularly on type 1601).**
  - **The top plate (4) must remain in position to prevent the safety diaphragm (5) from distorting.**
- ▶ Place the liquid end (2) with the screws (1) on the diaphragm (3) and the top plate (4) (the priming connector must point downwards once the pump is fully assembled).
  - ▶ Screw on screws (1) lightly and tighten (starting torque, see below).
  - ▶ For versions with coarse/fine bleed function, ensure that the liquid end cover engages in the liquid end, then push the coarse/fine bleed vent (knob) into the liquid end.

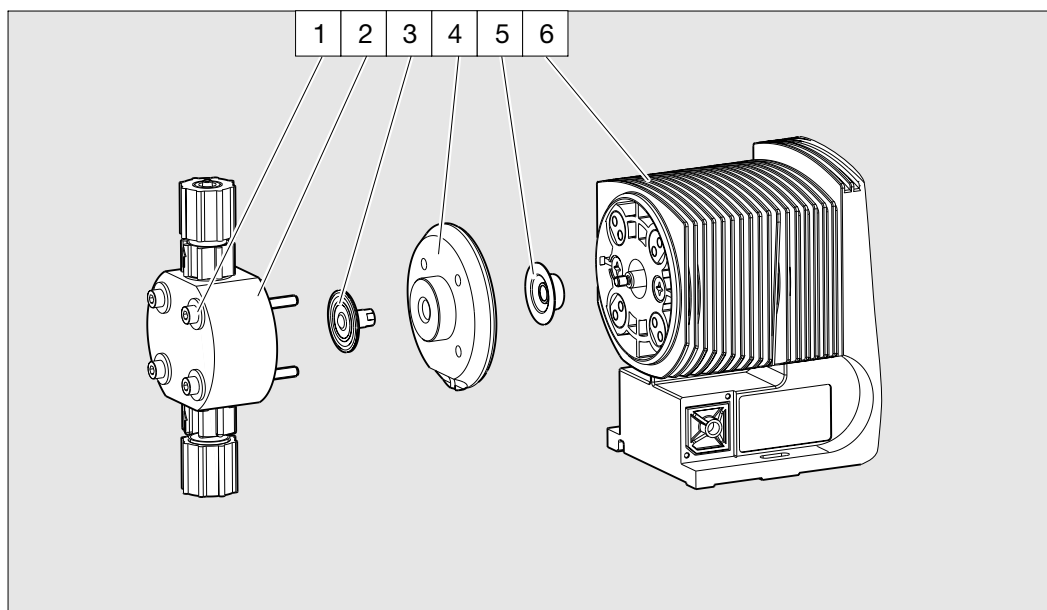

Fig. 21

- |              |                    |
|--------------|--------------------|
| 1 Screws     | 4 Top plate        |
| 2 Liquid end | 5 Safety diaphragm |
| 3 Diaphragm  | 6 Pump housing     |

**NOTE**

- **Check the screw torques after 24 hours in operation**
- **For PP liquid ends check the screw torques again after three months.**

Screw torques: 4,5 to 5 Nm

*Liquid ends - types 0220, 0232 and 0420*

- ▶ Remove the metering head (2) with the screw (1) from the pump (see fig. 22).
- ▶ Only type 0232: Remove the screws of the set disk (4) below the diaphragm (3).
- ▶ The screws (1) should fit in the holes of the diaphragm (3), but not on the set disk.
- ▶ Hold the housing (6) in one hand and with the other hand, clamp the diaphragm (3) between the liquid end (2) and the top plate (4); release the diaphragm (3) from the drive spindle with a light anti-clockwise turn of the liquid end (2) and top plate (4).
- ▶ Remove the liquid end (2) with screws (1) from of the diaphragm and unscrew completely from the drive spindle.
- ▶ Remove the top plate (4) from the housing (6).
- ▶ Check the condition of the safety diaphragm (5) and replace it necessary.
- ▶ Push the safety diaphragm (5) only as far onto the drive axis until it lies flat on the pump housing (6) – no further!
- ▶ Screw the new diaphragm (3) carefully up to the stop on the drive axis – this must be exact to ensure correct metering!
- ▶ Check that the holes in the diaphragm are aligned with those in the pump housing.
- ▶ If not, start the pump and set the stroke length to 100 %.
- ▶ When the pump is running, turn the diaphragm (3) slowly in a clockwise direction until the four holes in the diaphragm are flush with those on the pump housing (6).
- ▶ Hold the diaphragm (3) in this position, set the stroke length to 0 % and stop the pump.
- ▶ Screw the diaphragm (3) tight once more.
- ▶ Position the top plate (4) on the pump housing (6).
- ▶ Only type 0232: Mount the set disk (4) with the screws.

**IMPORTANT**

- The leakage hole must point downwards when the pump is fully assembled (see fig. 20).
  - Position the top plate (4) correctly on the pump housing (6). Do not distort the top plate on the pump housing, otherwise the safety diaphragm (5) will not fit.
- ▶ Lay the diaphragm (3) into the top plate (4).
- ▶ Hold the top plate and screw the diaphragm (3) in a clockwise direction until it is firmly in position (you will feel the resistance of the return spring).

**IMPORTANT**

- Do not overtighten the diaphragm (3).
  - The top plate (4) must remain in position to prevent the safety diaphragm (5) from distorting.
- ▶ Position the liquid end (2) with the screws (1) on the diaphragm (3) and the top plate (4) (the priming connector must point downwards once the pump is fully assembled).
- ▶ Screw on screws (1) lightly and tighten (starting torque, see above).
- ▶ For coarse/fine bleed versions: ensure the liquid end cover engages in the liquid end, then push the coarse/fine bleed (knob) into the liquid end.

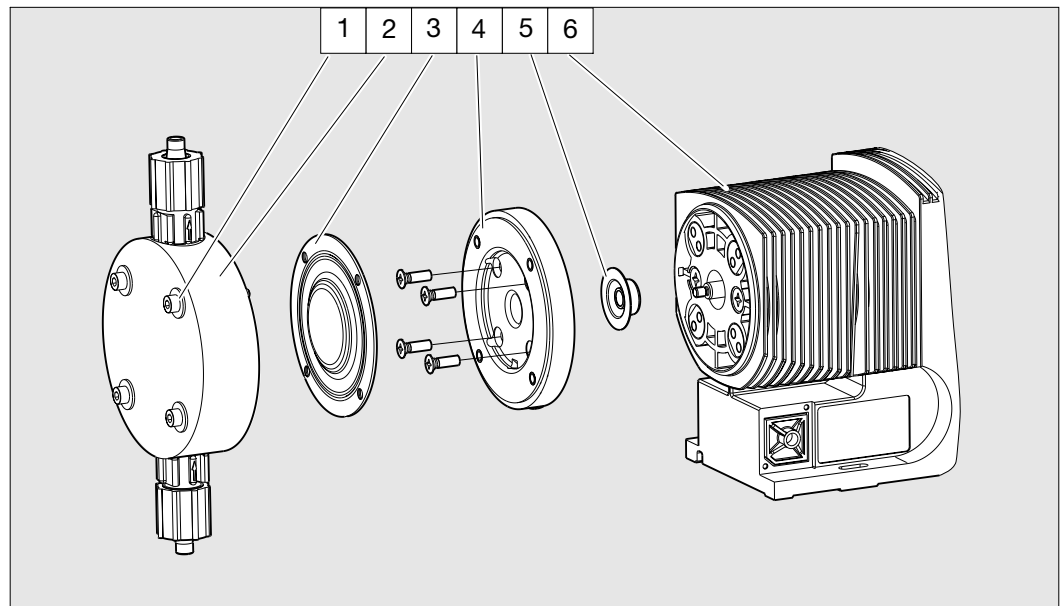

Fig. 22

- |              |                    |
|--------------|--------------------|
| 1 Screws     | 4 Top plate        |
| 2 Liquid end | 5 Safety diaphragm |
| 3 Diaphragm  | 6 Pump housing     |

**NOTE**

- Check the screw torque after 24 hours in operation!
- For PP liquid ends recheck the screw torque after three months!

## 11 Troubleshooting



### **WARNING**

- **Always take suitable precautions when using hazardous chemicals!**
- **Ensure the equipment is de-pressurised before working on the pump!**

### **gamma/ L does not prime despite full stroke and bleed function**

- Cause* Crystalline deposits on the ball seat because valves have dried out
- Remedy*
- ▶ Remove the suction sleeve from the chemical supply container and rinse out the liquid end thoroughly
  - ▶ If still unsuccessful, dismantle valves and clean (see section 9)

### **Fluid is seeping from the top plate**

- Cause* The liquid end is not sealed against the pump diaphragm
- Remedy*
- ▶ Tighten screws in the liquid end (see section 9)
  - ▶ If unsuccessful, replace the diaphragm (see section 10)

### **Green LED indicator (operating display) is not lit**

- Cause* Incorrect or no mains voltage
- Remedy*
- ▶ Use the recommended mains voltage as given in the voltage specification on the nameplate

### **Error Messages**

#### **Red LED display is lit, “Error” appears and “MINIM” flashes in the display**

- Cause* Fluid level in the chemical storage tank has reached “liquid level low, stage 2”
- Remedy*
- ▶ Fill the chemical supply container

#### **Red LED display is lit, “Error” appears and “ANALG” flashes in the display**

- Cause* gamma/ L is in “analogue” operating mode, a fault routine has been programmed in the ANALG menu and the operating current has fallen below 3.8 mA
- Remedy*
- ▶ Remedy low operating current
  - ▶ Switch fault routine “OFF” (see Section 7.4.2.)

#### **Red LED display is lit, “Error” appears and “CNTCT” flashes in the display**

- Cause* gamma/ L is in “contact” or “batch” operating mode and the extended function “memory” has been set.  
In addition a very large factor has been entered, too many contacts have been input or the P-key has been pressed too often, resulting in an overflow of the stroke memory.
- Remedy*
- ▶ Press the P-key, saved data will be deleted
  - ▶ Change gamma/ L set up

#### **Red LED display is lit, “Error” appears and “FLOW” flashes in the display**

- Cause* Dosing monitor not properly connected
- Remedy*
- ▶ Connect dosing monitor properly
  - ▶ Press P-key
- Cause* Dosing monitor has reported more defective strokes than have been set in the FLOW menu
- Remedy*
- ▶ Press P-key
  - ▶ Investigate the cause and remedy

#### **Red LED display is lit, “Error” appears and “Mem” flashes in the display**

- Cause* Stroke memory full
- Remedy*
- ▶ Remove cause
  - ▶ Press P-key (Consider the consequences this will have on your process)

### **All other Errors**

Please contact your ProMinent branch or representative!

## Fault Signals

### Yellow LED display is lit

*Cause* Liquid level in chemical storage tank has reached “liquid level low, stage 1”

*Remedy* ► Fill chemical storage tank

### Yellow LED Display is lit and “calib” flashes

*Cause* The pump is calibrated and the stroke length deviates by more than  $\pm 10\%$  from the value at the time of calibration.

*Remedy* ► Reset the stroke length or calibrate the pump again to the desired stroke length

## 12 Decommissioning and Disposal

### Decommissioning



#### WARNING

- **When decommissioning the gamma/ L the housing and, in particular, the liquid end must be thoroughly cleaned to remove chemicals and dirt!**
- **Always take suitable precautions when using hazardous chemicals!**
- **Ensure that the equipment is de-pressurised!**

► Disconnect the gamma/ L from the power supply

► Empty the liquid end by turning the gamma/ L upside down and allow the feed chemical to pour out

► Rinse the liquid end with a suitable material, thoroughly rinse the liquid end after use with hazardous materials!

If decommissioning is only temporary, maintain the correct storage conditions:

Storage temperature: -10 to +50 °C

Air humidity: < 92 % relative humidity

### Disposal



#### IMPORTANT

**Electronic waste is classified as special waste!**

Please observe all locally applicable directives!

## 13 Technical Data

### 13.1 Performance data and weights

gamma/ L

at 180 strokes/minute and 100 % stroke length

| Liquid end type | Max. feed rate at maximum operating pressure |      |         | max. feed rate at medium operating pressure |      |         | Connector size outer Ø x inner Ø<br>mm | Suction-lift*<br>m Wg | Priming-lift**<br>m Wg | Admmis. priming pressure<br>bar | Ship. Wt <sup>1</sup><br>approx. kg |
|-----------------|--|------|---------|---|------|---------|--|-----------------------|------------------------|---------------------------------|-------------------------------------|
|                 | bar  | l/h  | ml/str. | bar   | l/h  | ml/str. |  |                       |                        |                                 |                                     |
| 1000            | 10   | 0.74 | 0.09    | 5   | 0.82 | 0.076   | 6x4                                    | 6                     | 1.8                    | 8                               | 2.9 / 3.6                           |
| 1601            | 16   | 1.1  | 0.10    | 8   | 1.4  | 0.13    | 6x4                                    | 6                     | 2                      | 8                               | 2.9 / 3.6                           |
| 1602            | 16   | 2.1  | 0.19    | 8   | 2.5  | 0.24    | 6x4                                    | 6                     | 2                      | 5.5                             | 2.9 / 3.6                           |
| 1005            | 10   | 4.4  | 0.41    | 5   | 5.0  | 0.46    | 8x5****                                | 5                     | 3                      | 3                               | 3.1 / 4.5                           |
| 0708            | 7  | 7.1  | 0.66    | 3.5   | 8.4  | 0.78    | 8x5                                    | 6                     | 2                      | 2                               | 3.1 / 4.5                           |
| 0413            | 4  | 12.3 | 1.14    | 2   | 14.2 | 1.31    | 8x5                                    | 3                     | 2                      | 1.5                             | 3.1 / 4.5                           |
| 0220            | 2  | 19.0 | 1.76    | 1   | 20.9 | 1.94    | 12x9                                   | 2                     | 2                      | 1                               | 3.1 / 4.5                           |
| 1605            | 16   | 4.1  | 0.38    | 8   | 4.9  | 0.45    | 8x5****                                | 4                     | 3                      | 3                               | 4.5 / 5.9                           |
| 1008            | 10   | 6.8  | 0.63    | 5   | 8.3  | 0.76    | 8x5                                    | 3                     | 3                      | 2                               | 4.5 / 5.9                           |
| 0713            | 7  | 11.0 | 1.02    | 3.5   | 13.1 | 1.21    | 8x5                                    | 3                     | 3                      | 1.5                             | 4.5 / 5.9                           |
| 0420            | 4  | 17.1 | 1.58    | 2   | 19.1 | 1.77    | 12x9                                   | 3                     | 3                      | 1                               | 5.5 / 8.6                           |
| 0232            | 2  | 32.0 | 2.96    | 1   | 36.2 | 3.35    | 12x9                                   | 2                     | 2                      | 0.8                             | 5.5 / 8.6                           |

gamma/ L with self-degassing liquid end \*\*\*

at 180 strokes/minute and 100 % stroke length

| Liquid end type | Max. feed rate at maximum operating pressure |      |         | max. feed rate at medium operating pressure |      |         | Connector size outer Ø x inner Ø<br>mm | Suction-lift*<br>m Wg | Priming-lift**<br>m Wg | Admmis. priming pressure<br>bar | Ship. Wt <sup>1</sup><br>approx. kg |
|-----------------|--|------|---------|---|------|---------|--|-----------------------|------------------------|---------------------------------|-------------------------------------|
|                 | bar  | l/h  | ml/str. | bar   | l/h  | ml/str. |  |                       |                        |                                 |                                     |
| 1601            | 16   | 0.59 | 0.055   | 8   | 0.78 | 0.072   | 6x4                                    | –                     | 1.8                    | 0.5                             | 2.9                                 |
| 1602            | 16   | 1.4  | 0.13    | 8   | 1.74 | 0.16    | 6x4                                    | –                     | 2.1                    | 0.5                             | 2.9                                 |
| 1005            | 10   | 3.6  | 0.33    | 5   | 4.0  | 0.37    | 8x5                                    | –                     | 2.7                    | 0.5                             | 3.1                                 |
| 0708            | 7  | 6.6  | 0.61    | 3.5   | 7.5  | 0.69    | 8x5                                    | –                     | 2                      | 0.5                             | 3.1                                 |
| 0413            | 4  | 10.8 | 1.00    | 2   | 12.6 | 1.17    | 8x5                                    | –                     | 2.5                    | 0.5                             | 3.1                                 |
| 0220            | 2  | 16.3 | 0.31    | 8   | 3.8  | 0.35    | 8x5                                    | –                     | 3.0                    | 0.5                             | 4.5                                 |
| 1008            | 10   | 6.3  | 0.58    | 5   | 7.5  | 0.69    | 8x5                                    | –                     | 3.0                    | 0.5                             | 4.5                                 |
| 0713            | 7  | 10.5 | 0.97    | 3.5   | 12.3 | 1.14    | 8x5                                    | –                     | 2.5                    | 0.5                             | 4.5                                 |
| 0420            | 4  | 15.6 | 1.44    | 2   | 17.4 | 1.61    | 12x9                                   | –                     | 2.5                    | 0.5                             | 4.5                                 |

\* Lift when suction line and liquid end are full

\*\* Priming lift with clean and wetted valves, priming lift at 100% stroke length and free flow or opened bleed valve

\*\*\* The feed rate values are for minimum feed rates, based on water at 20° C

\*\*\*\* For material versions SST : 6 x 4 mm

<sup>1</sup> For material versions PPE, PPB, NPE, NPB, PVT, TTT/SST

<sup>2</sup> For material versions PPE, PPB, NPE, NPB



### 13.2 Dosing reproducibility

#### Standard Liquid ends

*Dosing precision* -5 to +10 % at max. stroke length and max. operating pressure for all materials.

*Reproducibility* ±2 % at constant conditions and minimum 30 % stroke length.

#### Self-degassing liquid ends

Since self-degassing liquid ends are filled with air bubbles when in contact with gaseous chemicals and when in operation, no dosing reproducibility values can be given.

The recommended minimum stroke length with self-degassing liquid ends is 50 %.

### 13.3 Viscosity

The liquid ends are designed for liquids up to a maximum viscosity of

- 200 mPas for standard liquid ends
- 500 mPas for valves with springs
- 50 mPas for self-degassing liquid ends

### 13.4 Materials Data

#### Liquid ends

| Version | Liquid end                | Valves                    | Seals | Balls   |
|---------|---------------------------|---------------------------|-------|---------|
| PPE     | PP                        | PP                        | EPDM  | Ceramic |
| PPB     | PP                        | PP                        | FPM   | Ceramic |
| NPE     | Acrylic glass             | PVC                       | EPDM  | Ceramic |
| NPE     | Acrylic glass             | PVC                       | FPM   | Ceramic |
| PVT     | PVDF                      | PTFE with carbon          | PTFE  | Ceramic |
| TTT     | PTFE with carbon          | PTFE with carbon          | PTFE  | Ceramic |
| SST     | Stainless steel<br>1.4571 | Stainless steel<br>1.4571 | PTFE  | Ceramic |

FPM = Fluorine Rubber

#### Pump

Housing Polyphenylene ether (PPE with glass fibre)

Cover Polycarbonate

Electronics Electronic components

### 13.5 Electrical Data

Version: 100 - 230 V ±10 %, 50/60 Hz

| Varants 100 - 230 V/AC | gamma/ L M70            | gamma/ L M85            |
|------------------------|-------------------------|-------------------------|
| Power rating           | 17 W                    | 22 W                    |
| Rated current          | 0.7 A                   | 1 A                     |
| Switch on peak current | 15 A (for approx. 1 ms) | 15 A (for approx. 1 ms) |
| Fuse                   | 0.8 AT                  | 0.8 AT                  |

*Note* Fuses must display VDE, UL and CSA certification, e.g. type 19195 from Wickmann in accordance with IEC publication 127 - 2/3

### 13.6 Ambient conditions

*Temperatures* Storage and transport temperatures: -10 to +50 °C  
 Feed chemical temperature: -10 to +35 °C  
 Ambient temperature when in operation: -10 to +45 °C (drive and control)

Maximum ambient temperatures for liquid ends depending on material type:

| max. ambient temperature               | PPE, PPB | NPE, NPB | PVT    | TTT    | SST    |
|--|----------|----------|--------|--------|--------|
| Long-term at max. operating pressure   | 50 °C    | 45 °C    | 50 °C  | 50 °C  | 50 °C  |
| Short term (max. 15 min) at max. 2 bar | 100 °C   | 60 °C    | 120 °C | 120 °C | 120 °C |

\* Under extreme conditions such as maximum dosing temperatures, maximum stroke frequency and maximum operating pressure, leakage can occur on the liquid end at an ambient temperature of 35 °C.

*Climate* Permissible air humidity: 92 % relative humidity, not condensing  
 Moist and fluctuating air conditions: FW 24 in accordance with DIN 50016

### 13.7 Enclosure rating and safety class

*Enclosure Rating* Contact and moisture enclosure rating:  
 IP 65 in accordance with IEC 529, EN 60529, DIN VDE 0470 Part 1

*Safety Requirements* Safety Class 1 - Mains connection with earth lead

### 13.8 Compatibility

The hydraulic parts of the gamma/ L are identical to those of the Beta®.  
 The following components and accessories for pumps from the product ranges Beta®, CONCEPT, gamma-Classic and gamma are all compatible:

- gamma/Vario signal cable; 2-, 4- and 5 core for “external” function
- 2 stage float switch (gamma/Vario)
- Discharge tubing diameters
- Standard gamma connector set
- gamma wall bracket
- Chemical feed containers and mounting plates
- Total height (distance between suction and discharge connector)
- Distance between the connectors and locating holes on the pumps
- Accessories such as pressure back pressure valve, multifunctional valve, dosing monitor and rinsing equipment

PPE, PPB material versions

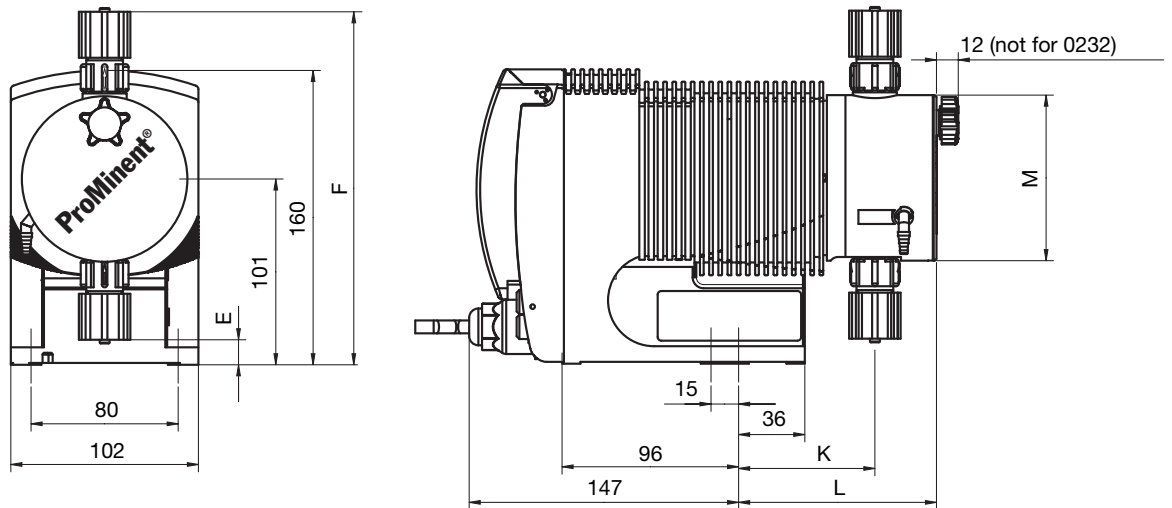

Fig. 23

Dimensions in mm

|          | gamma/ L M70 |      |             |      | gamma/ L M85 |             |      |       |
|----------|--------------|------|-------------|------|--------------|-------------|------|-------|
|          | 1000 - 1602  | 1005 | 0708 - 0413 | 0220 | 1605         | 1008 - 0713 | 0420 | 0232  |
| <b>E</b> | 23           | 13   | 15          | 15   | 13           | 15          | 15   | 5     |
| <b>F</b> | 186          | 193  | 191         | 191  | 193          | 191         | 191  | 197   |
| <b>K</b> | 71           | 71   | 74          | 76   | 71           | 74          | 76   | 76    |
| <b>L</b> | 106          | 105  | 108         | 110  | 105          | 108         | 110  | 91    |
| <b>M</b> | Ø 70         | Ø 90 | Ø 90        | Ø 90 | Ø 90         | Ø 90        | Ø 90 | Ø 110 |

NPE, NPB material versions (non bleed)

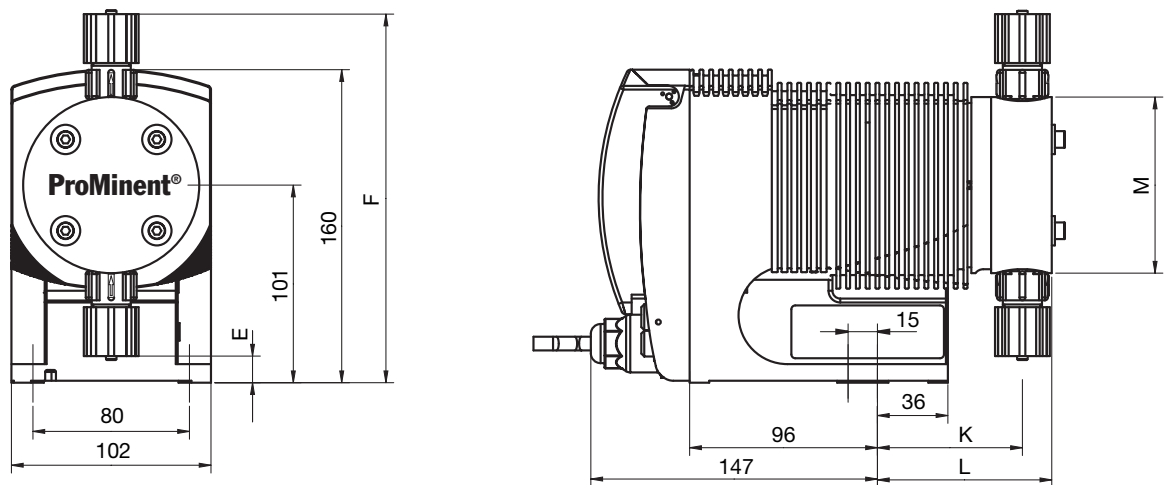

Fig. 24

Dimensions in mm

|          | gamma/ L M70 |           |      |      |             | gamma/ L M85 |             |      |       |
|----------|--------------|-----------|------|------|-------------|--------------|-------------|------|-------|
|          | 1000 - 1601  | 1602      | 1005 | 0708 | 0413 - 0220 | 1605         | 1008 - 0713 | 0420 | 0232  |
| <b>E</b> | 25           | 23        | 16   | 15   | 15          | 16           | 15          | 15   | 5     |
| <b>F</b> | 177          | 179       | 188  | 189  | 189         | 188          | 189         | 189  | 199   |
| <b>K</b> | 77           | 77        | 74   | 74   | 76          | 74           | 74          | 76   | 76    |
| <b>L</b> | 92           | 92        | 89   | 89   | 91          | 89           | 89          | 91   | 91    |
| <b>M</b> | 62 (Ø 70)    | 66 (Ø 70) | Ø 90 | Ø 90 | Ø 90        | Ø 90         | Ø 90        | Ø 90 | Ø 110 |

NPE, NPB material versions (with bleed function)

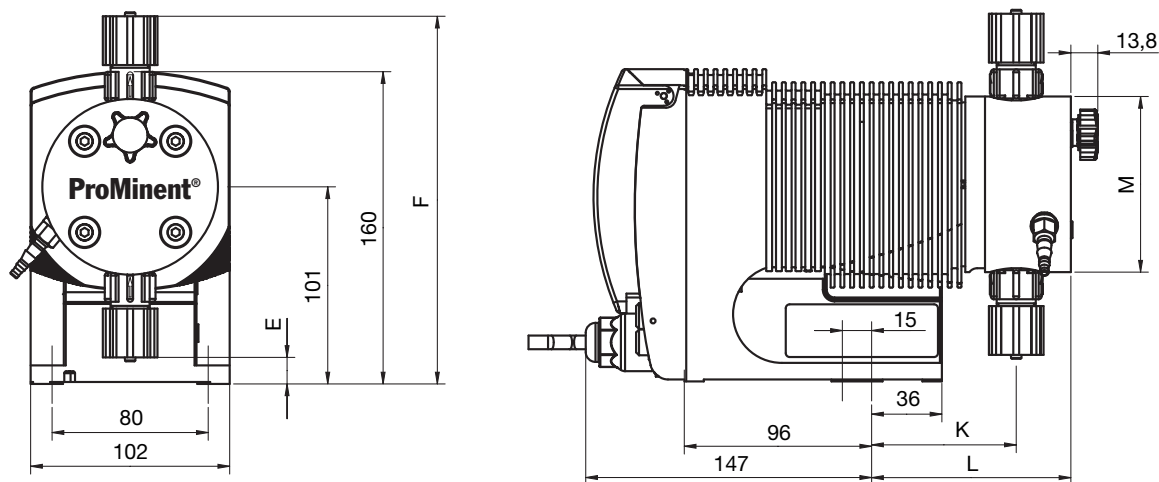

Fig. 25

Dimensions in mm

|          | gamma/ L M70 |           |      |      |             | gamma/ L M85 |      |             |       |
|----------|--------------|-----------|------|------|-------------|--------------|------|-------------|-------|
|          | 1000 - 1601  | 1602      | 1005 | 0708 | 0413 - 0220 | 1605         | 1008 | 0713 - 0420 | 0232  |
| <b>E</b> | 25           | 23        | 16   | 13   | 15          | 16           | 13   | 15          | 5     |
| <b>F</b> | 177          | 179       | 188  | 189  | 189         | 188          | 189  | 189         | 199   |
| <b>K</b> | 77           | 77        | 74   | 74   | 76          | 74           | 74   | 76          | 76    |
| <b>L</b> | 105          | 105       | 102  | 102  | 104         | 102          | 102  | 104         | 105   |
| <b>M</b> | 62 (Ø 70)    | 66 (Ø 70) | Ø 90 | Ø 90 | Ø 90        | Ø 90         | Ø 90 | Ø 90        | Ø 110 |

PPE, PPB, NPE, NPB, SEK material versions

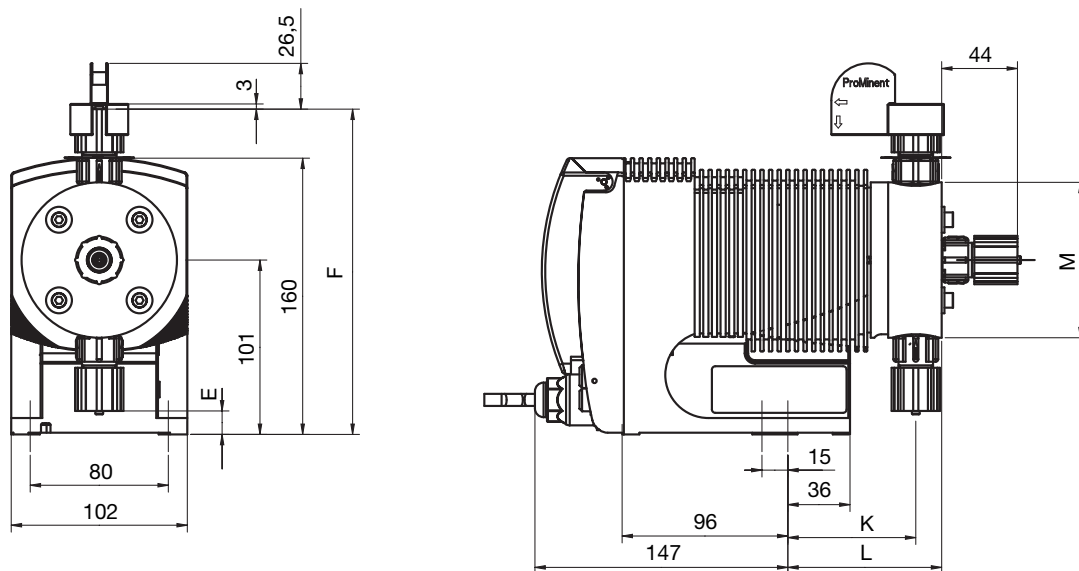

Fig. 26

Dimensions in mm

|          | gamma/ L M70 |           |      |      |             | gamma/ L M85 |             |      |
|----------|--------------|-----------|------|------|-------------|--------------|-------------|------|
|          | 1601         | 1602      | 1005 | 0708 | 0413 - 0220 | 1605         | 1008 - 0713 | 0420 |
| <b>E</b> | 25           | 23        | 16   | 15   | 15          | 16           | 15          | 15   |
| <b>F</b> | 177          | 179       | 188  | 189  | 189         | 188          | 189         | 189  |
| <b>K</b> | 77           | 77        | 74   | 74   | 76          | 74           | 74          | 76   |
| <b>L</b> | 92           | 92        | 89   | 89   | 91          | 89           | 89          | 91   |
| <b>M</b> | 62 (Ø 60)    | 66 (Ø 70) | Ø 90 | Ø 90 | Ø 90        | Ø 90         | Ø 90        | Ø 90 |

PVDF material version

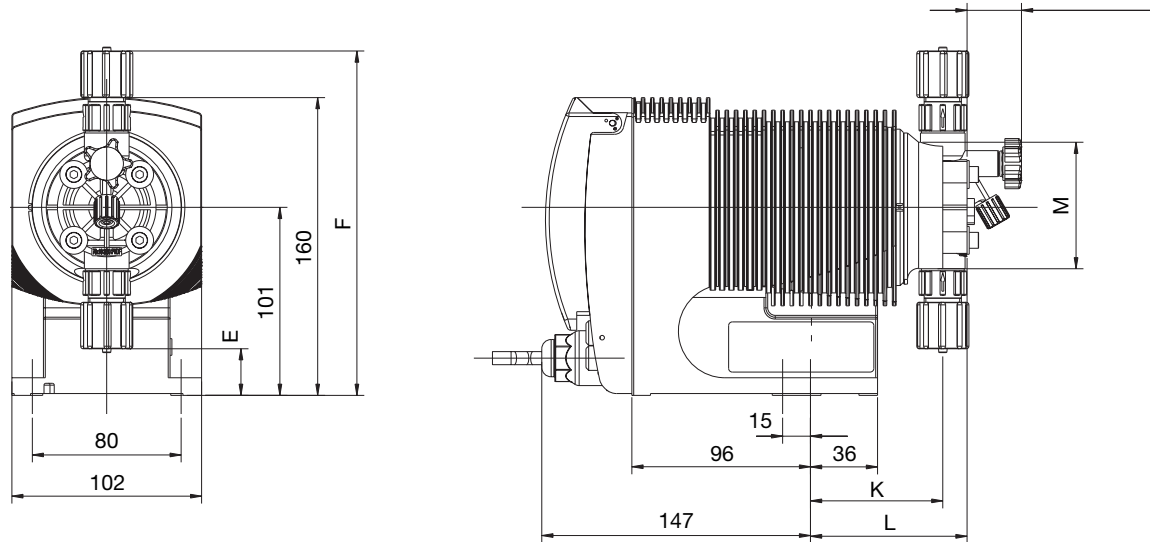

Fig. 27

Dimensions in mm

|          | gamma/ L M70 |      |           |      | gamma/ L M85 |           |      |       |
|----------|--------------|------|-----------|------|--------------|-----------|------|-------|
|          | 1000-1602    | 1005 | 0708-0413 | 0220 | 1605         | 0408-0713 | 0420 | 0232  |
| <b>E</b> | 25           | 14   | 14        | 14   | 14           | 14        | 14   | 4     |
| <b>F</b> | 185          | 191  | 191       | 191  | 191          | 191       | 191  | 198   |
| <b>K</b> | 71           | 71   | 73        | 75   | 71           | 73        | 75   | 76    |
| <b>L</b> | 84           | 88   | 90        | 92   | 88           | 90        | 92   | 93    |
| <b>M</b> | Ø 70         | Ø 90 | Ø 90      | Ø 90 | Ø 90         | Ø 90      | Ø 90 | Ø 110 |

TTT material version

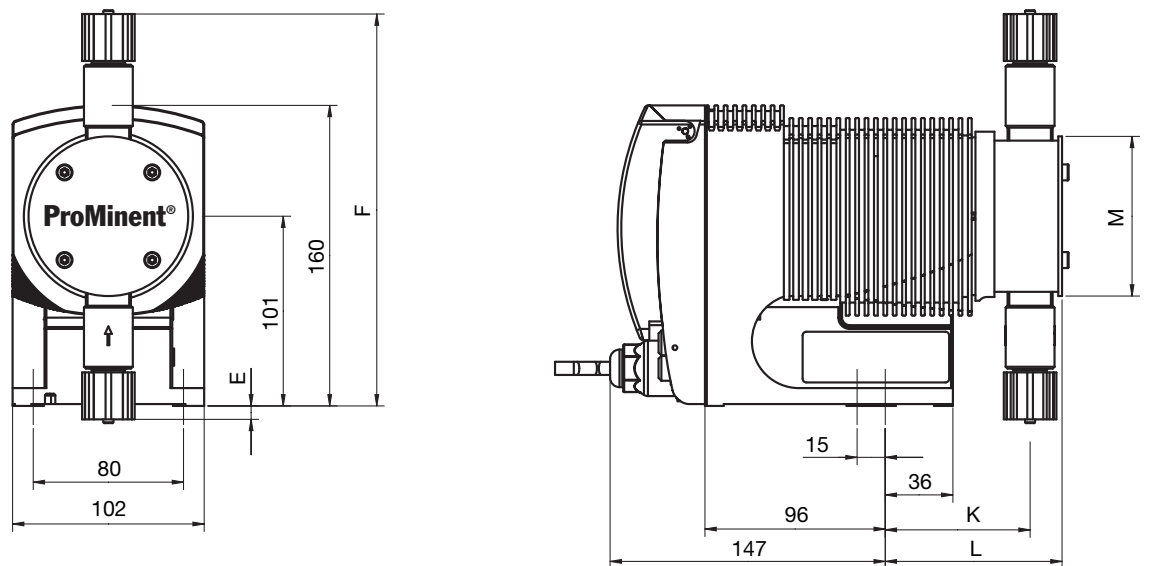

Fig. 28

Dimensions in mm

|          | gamma/ L M70 |           |           |             | gamma/ L M85 |             |            |
|----------|--------------|-----------|-----------|-------------|--------------|-------------|------------|
|          | 1000 - 1601  | 1602      | 1005      | 0708 - 0220 | 1605         | 1008 - 0420 | 0232       |
| <b>E</b> | 32           | 25        | 23        | -7          | 23           | -7          | -15        |
| <b>F</b> | 170          | 178       | 179       | 209         | 179          | 209         | 217        |
| <b>K</b> | 78           | 72        | 75        | 77          | 75           | 77          | 78         |
| <b>L</b> | 91           | 87        | 90        | 95          | 90           | 95          | 97         |
| <b>M</b> | 51 (Ø 60)    | 66 (Ø 70) | 68 (Ø 80) | 81 (Ø 85)   | 68 (Ø 80)    | 81 (Ø 85)   | 96 (Ø 100) |

SST material version

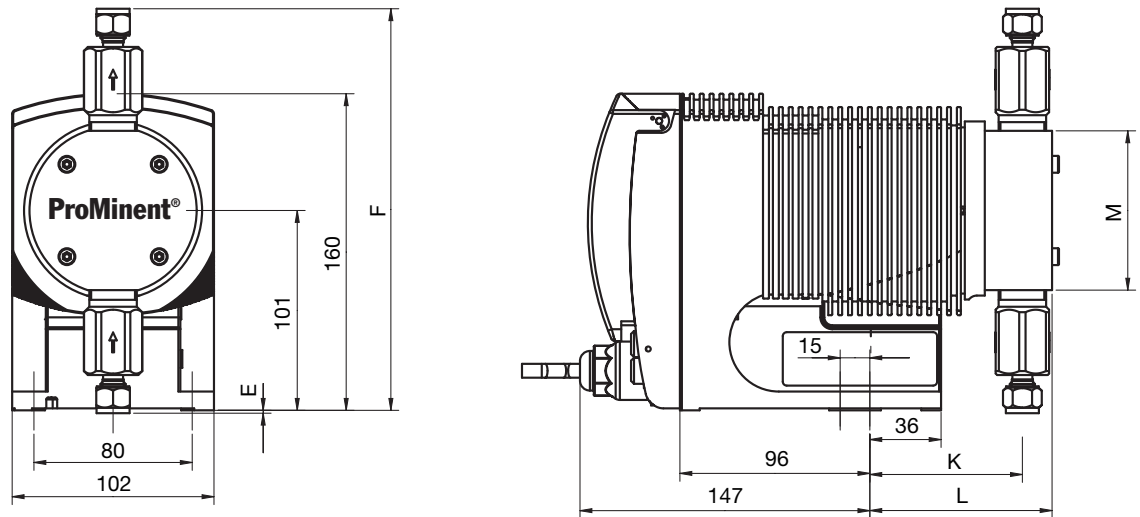
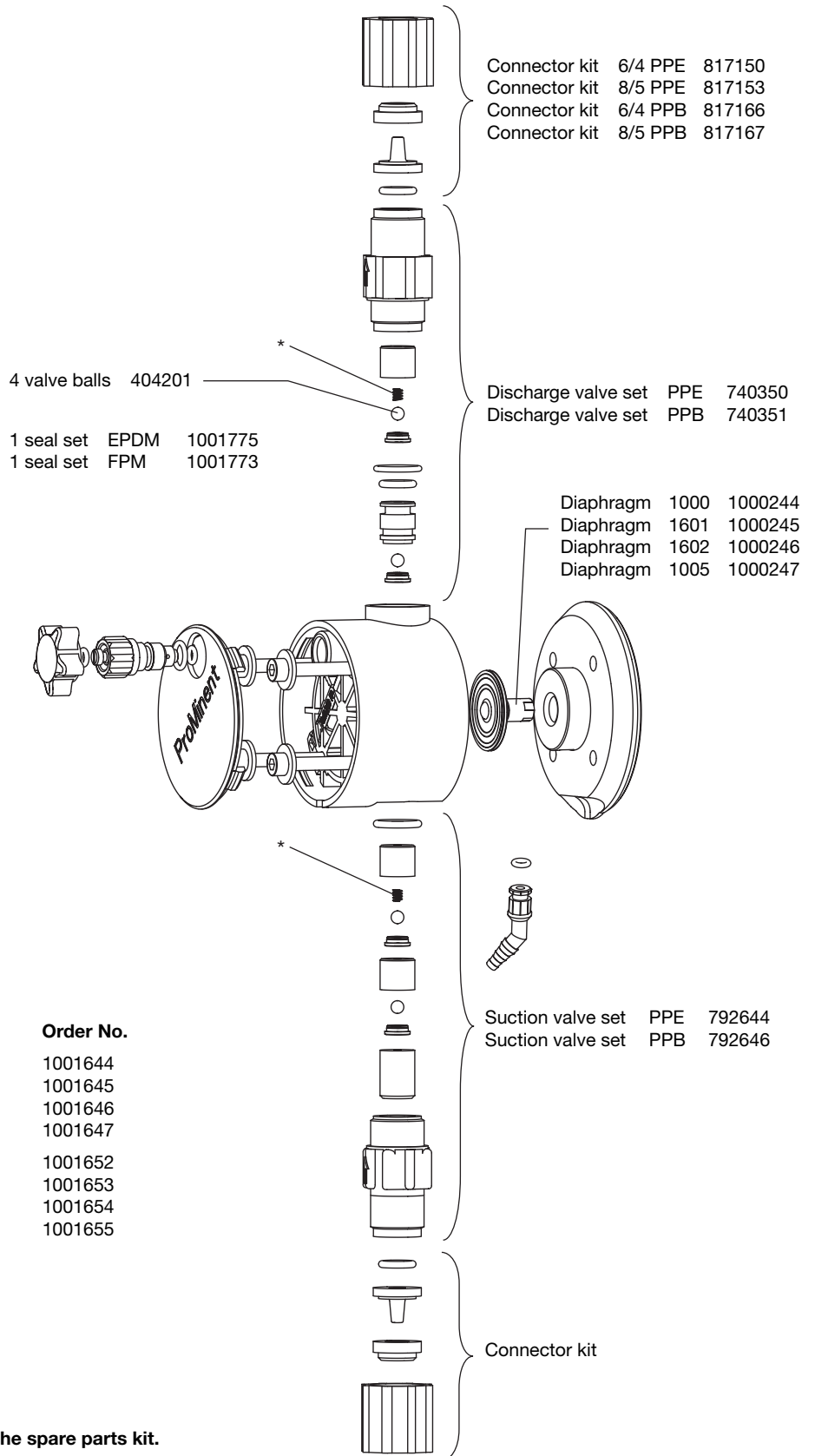

Fig. 29

Dimensions in mm

|          | gamma/ L M70 |           |           |             |           | gamma/ L M85 |             |           |            |
|----------|--------------|-----------|-----------|-------------|-----------|--------------|-------------|-----------|------------|
|          | 1000 - 1601  | 1602      | 1005      | 0708 - 0413 | 0220      | 1605         | 1008 - 0713 | 0420      | 0232       |
| <b>E</b> | 40           | 33        | 31        | -2          | -3        | 31           | -2          | -3        | -10        |
| <b>F</b> | 162          | 170       | 171       | 203         | 204       | 171          | 203         | 204       | 212        |
| <b>K</b> | 78           | 72        | 75        | 77          | 77        | 75           | 77          | 77        | 78         |
| <b>L</b> | 89           | 85        | 88        | 93          | 93        | 88           | 93          | 93        | 95         |
| <b>M</b> | 51 (Ø 60)    | 66 (Ø 70) | 68 (Ø 80) | 81 (Ø 85)   | 81 (Ø 85) | 81 (Ø 80)    | 81 (Ø 85)   | 81 (Ø 85) | 96 (Ø 100) |

**Liquid end 1000 - 1005 (1605)  
PP with coarse/fine bleed**



**Spare parts kits for:**

| Type        | Material | Order No. |
|-------------|----------|-----------|
| 1000        | PPE      | 1001644   |
| 1601        | PPE      | 1001645   |
| 1602        | PPE      | 1001646   |
| 1005 (1605) | PPE      | 1001647   |
| 1000        | PPB      | 1001652   |
| 1601        | PPB      | 1001653   |
| 1602        | PPB      | 1001654   |
| 1005 (1605) | PPB      | 1001655   |

The listed items are included in the spare parts kit.  
\* Customer accessories

Subject to technical alterations.

60\_07-104\_00\_18-04\_2

Liquid end 0708 (1008) - 0220 (0420)  
PP with coarse/fine bleed

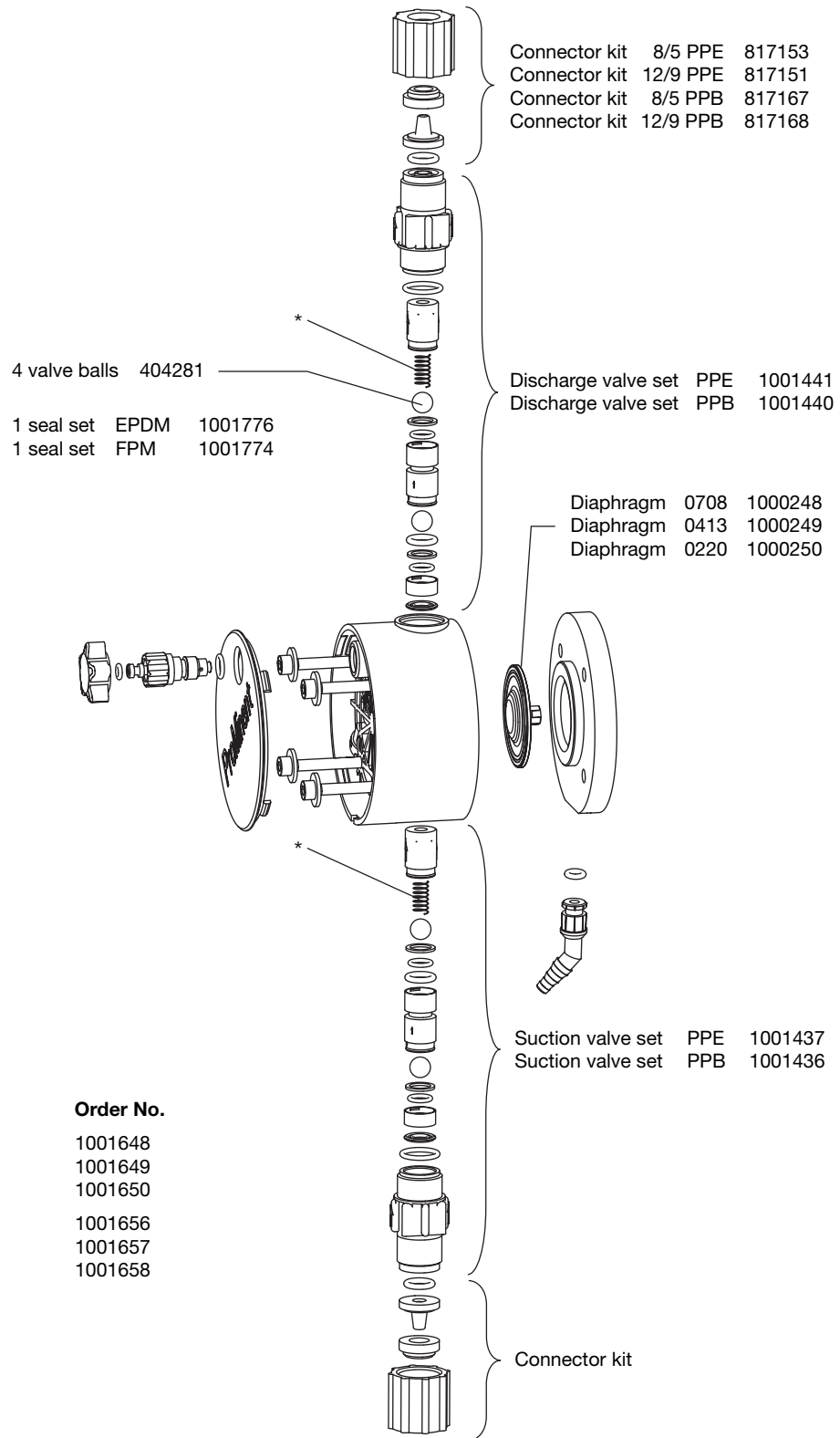

Spare parts kits for:

| Type        | Material | Order No. |
|-------------|----------|-----------|
| 0708 (1008) | PPE      | 1001648   |
| 0413 (0713) | PPE      | 1001649   |
| 0220 (0420) | PPE      | 1001650   |
| 0708 (1008) | PPB      | 1001656   |
| 0413 (0713) | PPB      | 1001657   |
| 0220 (0420) | PPB      | 1001658   |

The listed items are included in the spare parts kit.

\* Customer accessories

Subject to technical alterations.

60\_07-104\_00\_19-04\_2



Liquid end 0232  
PP without coarse/fine bleed

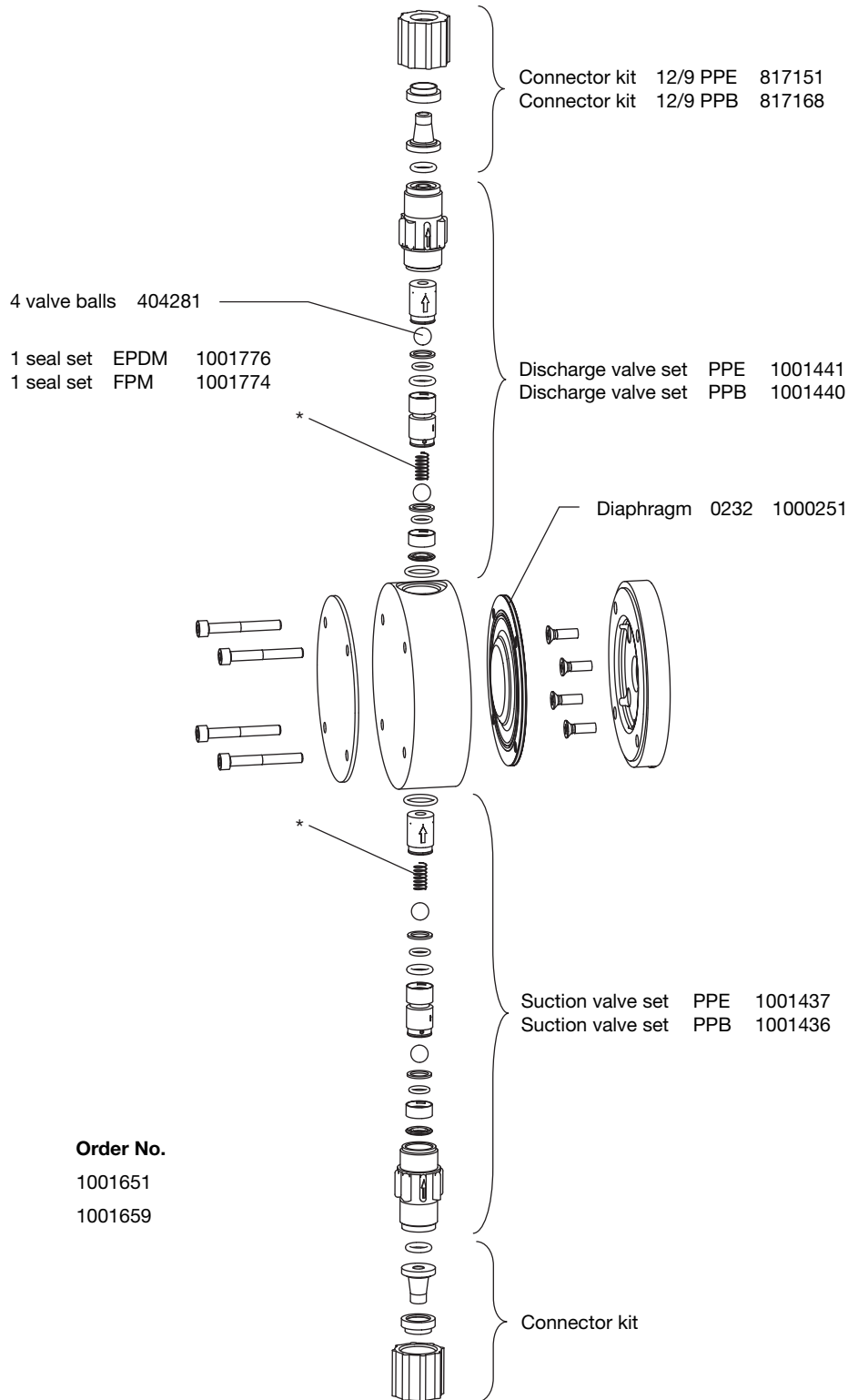

Spare parts kits for:

| Type | Material | Order No. |
|------|----------|-----------|
| 0232 | PPE      | 1001651   |
| 0232 | PPB      | 1001659   |

The listed items are included in the spare parts kit.  
\* Customer accessories

Subject to technical alterations.

60\_07-104\_00\_40-04\_2

**Liquid end 1000 - 1005 (1605)  
NP with coarse/fine bleed**

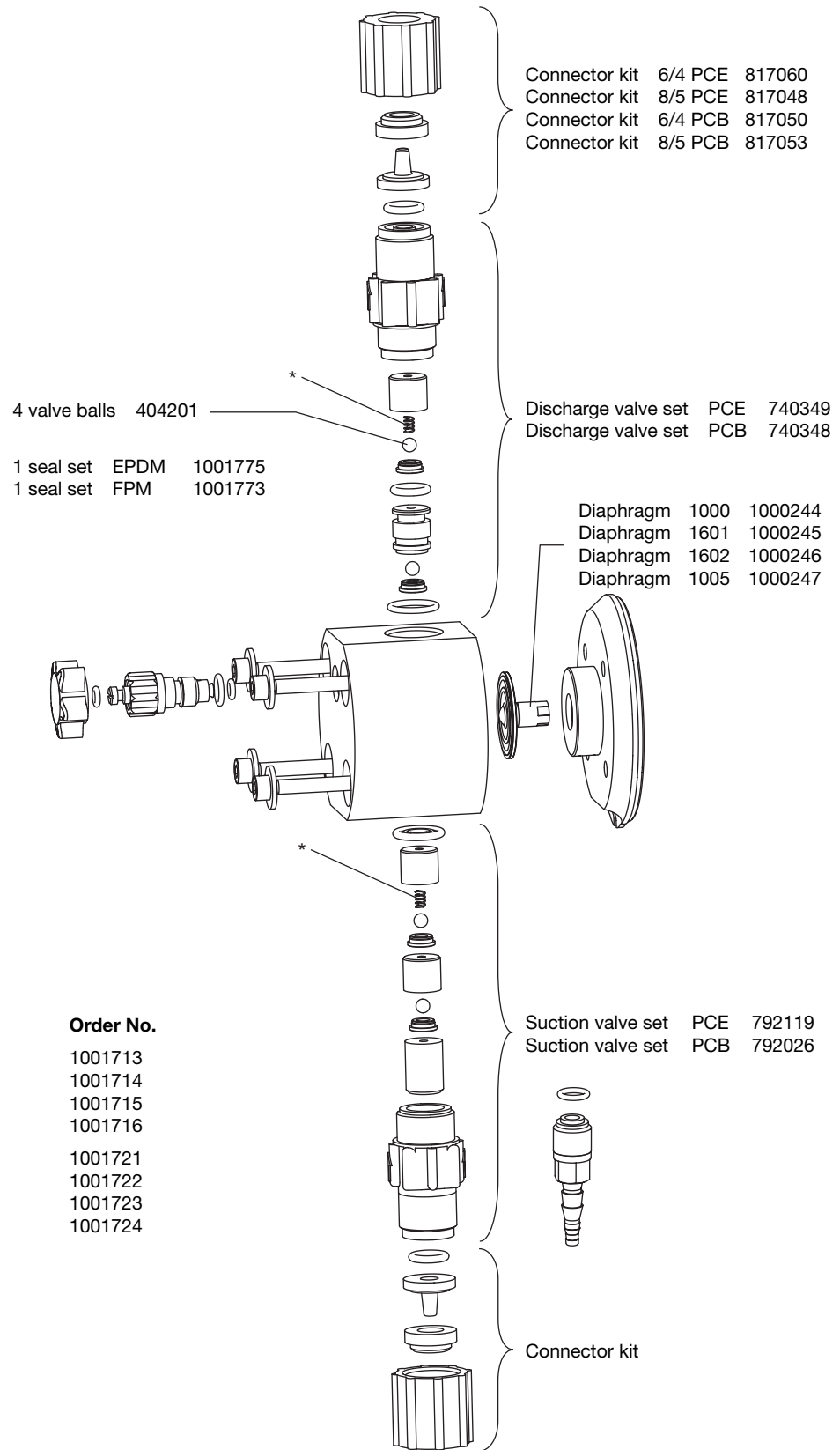

**Spare parts kits for:**

| Type        | Material | Order No. |
|-------------|----------|-----------|
| 1000        | NPE      | 1001713   |
| 1601        | NPE      | 1001714   |
| 1602        | NPE      | 1001715   |
| 1005 (1605) | NPE      | 1001716   |
| 1000        | NPB      | 1001721   |
| 1601        | NPB      | 1001722   |
| 1602        | NPB      | 1001723   |
| 1005 (1605) | NPB      | 1001724   |

The listed items are included in the spare parts kit.

\* Customer accessories

Subject to technical alterations.

60\_07-104\_00\_23-04\_2

**Liquid end 0708 (1008) - 0220 (0420)**  
**NP with coarse/fine bleed**

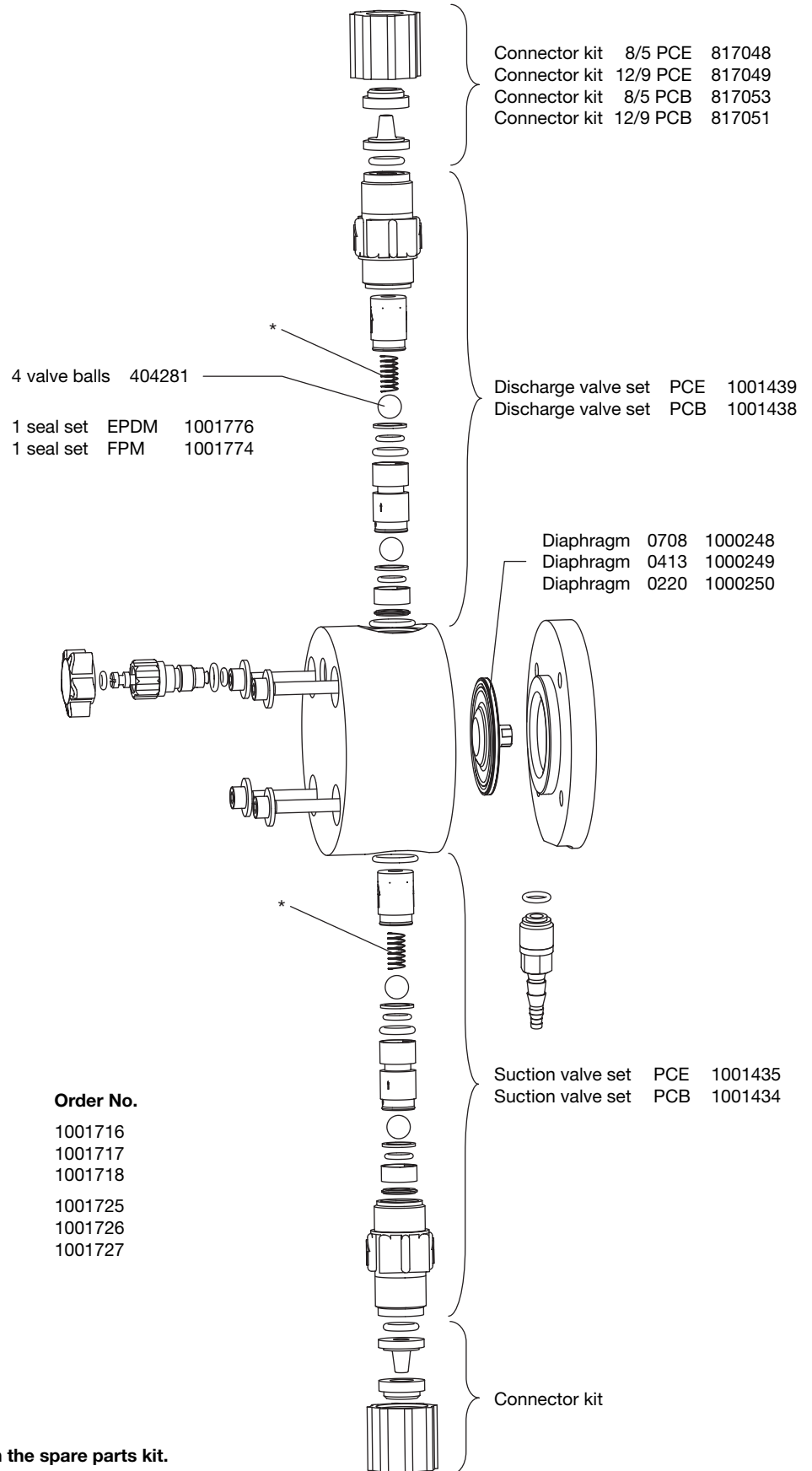

**Spare parts kits for:**

| Type        | Material | Order No. |
|-------------|----------|-----------|
| 0708 (1008) | NPE      | 1001716   |
| 0413 (0713) | NPE      | 1001717   |
| 0220 (0420) | NPE      | 1001718   |
| 0708 (1008) | NPB      | 1001725   |
| 0413 (0713) | NPB      | 1001726   |
| 0220 (0420) | NPB      | 1001727   |

The listed items are included in the spare parts kit.  
 \* Customer accessories

Subject to technical alterations.

Liquid end 0232  
NP with coarse/fine bleed

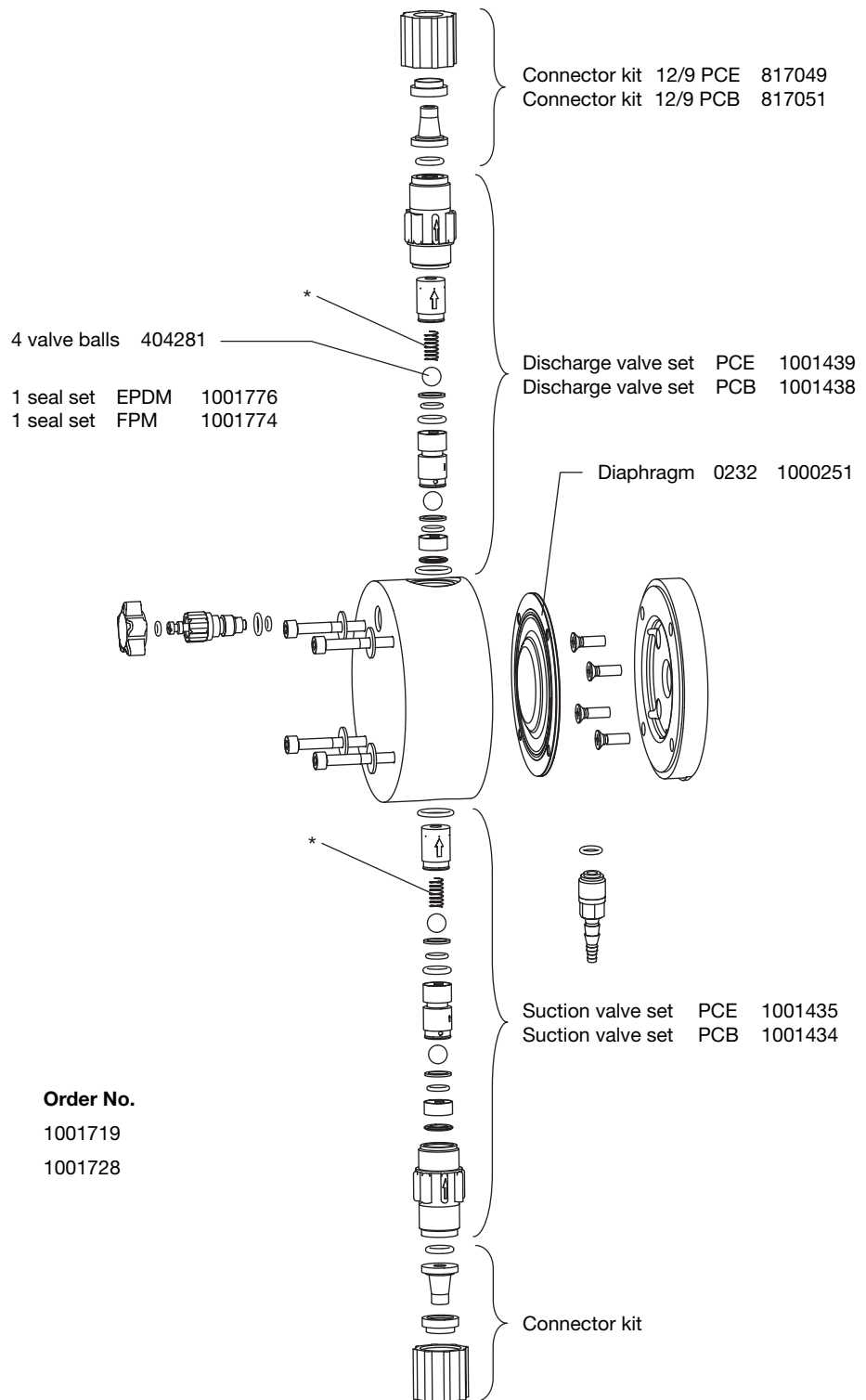

Spare parts kits for:

| Type | Material | Order No. |
|------|----------|-----------|
| 0232 | NPE      | 1001719   |
| 0232 | NPB      | 1001728   |

The listed items are included in the spare parts kit.

\* Customer accessories

Subject to technical alterations.

60\_07-104\_00\_34-04\_2

**Liquid end 1000 - 1005 (1605)  
NP without coarse/fine bleed**

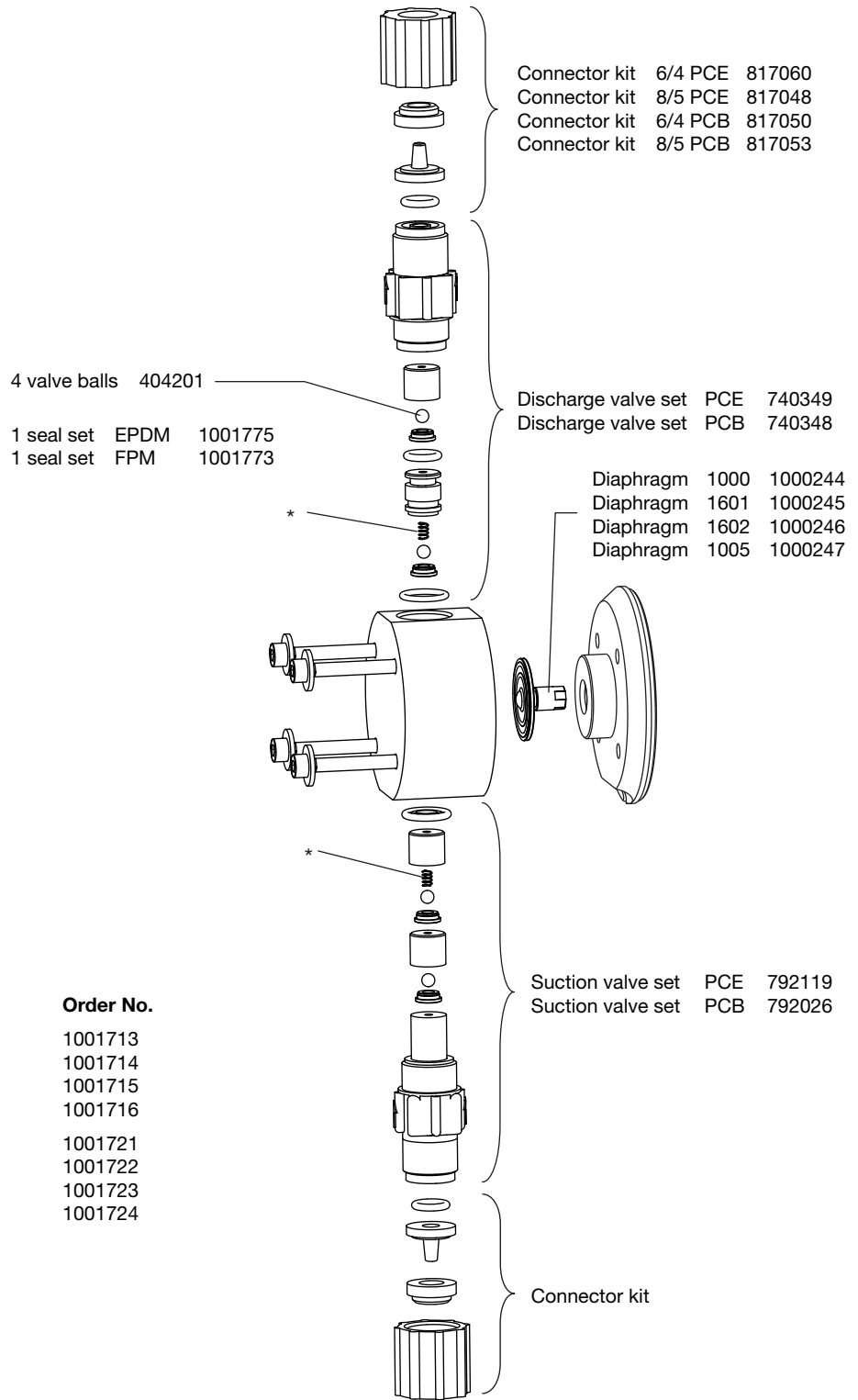

**Spare parts kits for:**

| Type        | Material  | Order No. |
|-------------|-----------|-----------|
| 1000        | PCE / NPE | 1001713   |
| 1601        | PCE / NPE | 1001714   |
| 1602        | PCE / NPE | 1001715   |
| 1005 (1605) | PCE / NPE | 1001716   |
| 1000        | PCB / NPB | 1001721   |
| 1601        | PCB / NPB | 1001722   |
| 1602        | PCB / NPB | 1001723   |
| 1005 (1605) | PCB / NPB | 1001724   |

The listed items are included in the spare parts kit.  
\* Customer accessories

Subject to technical alterations.

60\_07-104\_00\_21-04\_2

Liquid end 0708 (1008) - 0220 (0420)  
NP without coarse/fine bleed

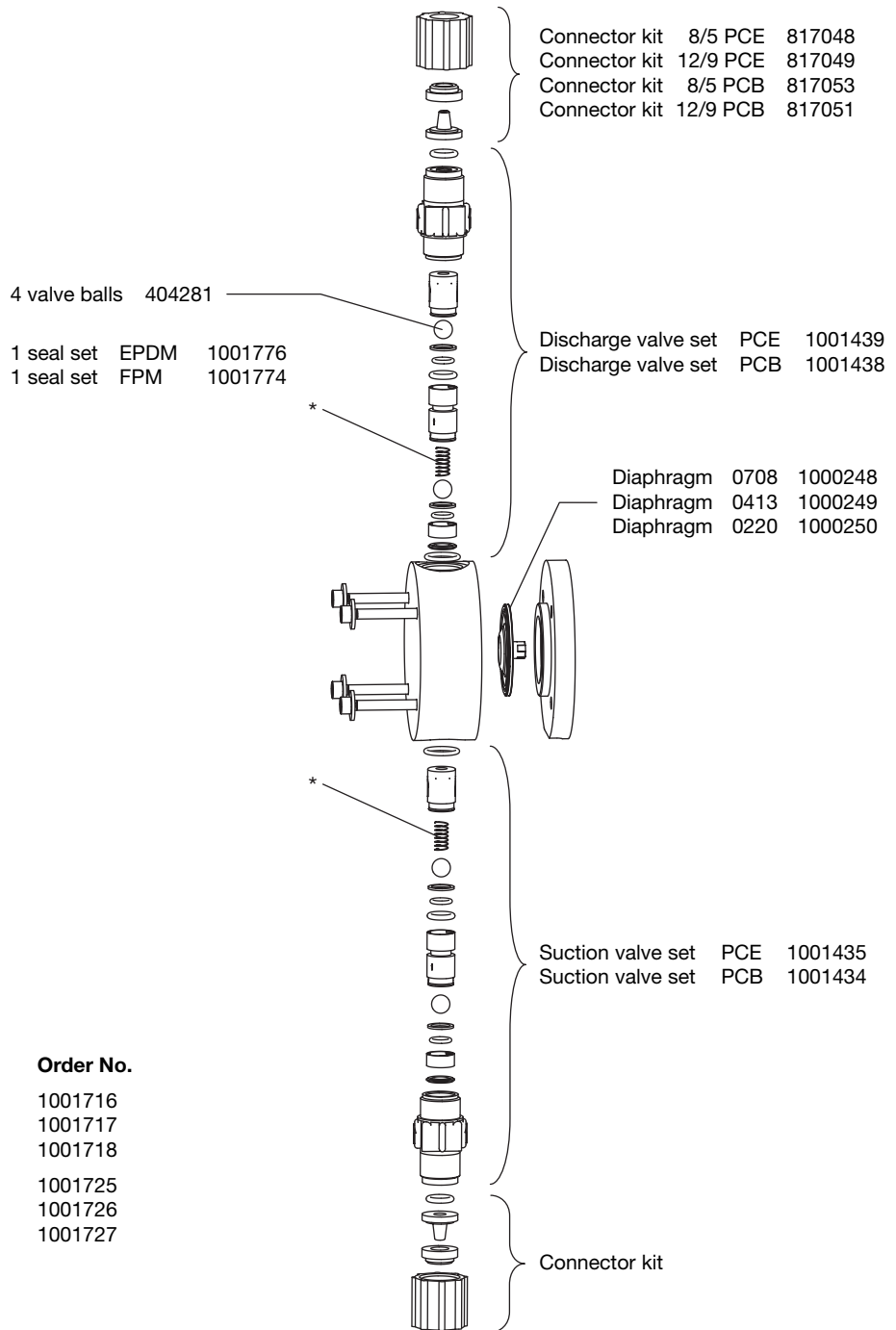

Spare parts kits for:

| Type        | Material | Order No. |
|-------------|----------|-----------|
| 0708 (1008) | NPE      | 1001716   |
| 0413 (0713) | NPE      | 1001717   |
| 0220 (0420) | NPE      | 1001718   |
| 0708 (1008) | NPB      | 1001725   |
| 0413 (0713) | NPB      | 1001726   |
| 0220 (0420) | NPB      | 1001727   |

The listed items are included in the spare parts kit.

\* Customer accessories

Subject to technical alterations.

60\_07-104\_00\_22-04\_2

**Liquid end 0232**  
**NP without coarse/fine bleed**

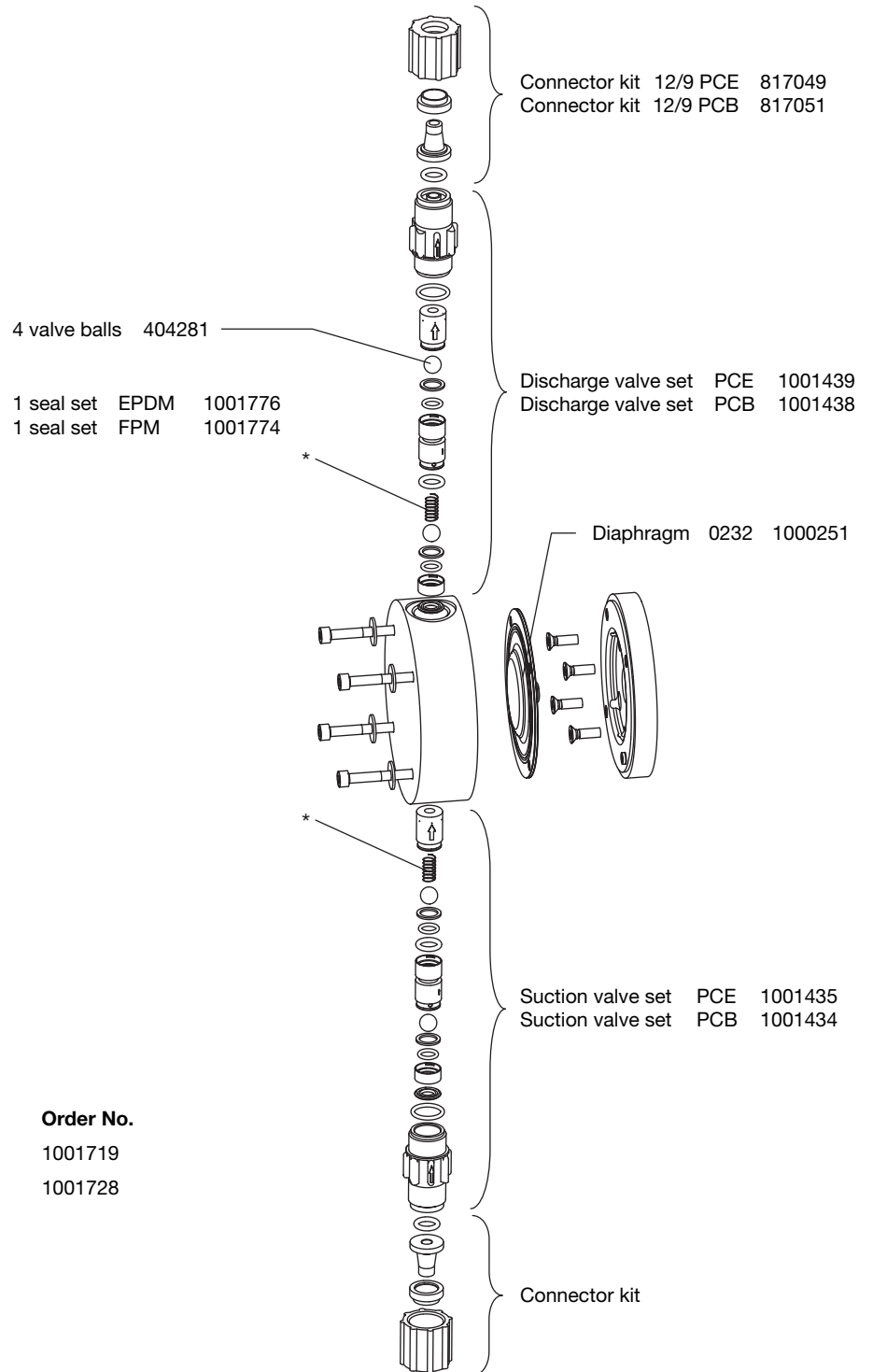

**Spare parts kits for:**

| Type | Material | Order No. |
|------|----------|-----------|
| 0232 | NPE      | 1001719   |
| 0232 | NPB      | 1001728   |

The listed items are included in the spare parts kit.  
 \* Customer accessories

Subject to technical alterations.

60\_07-104\_00\_20-04\_2

Liquid end 1601 - 1005 (1605)  
PP / NP self-degassing

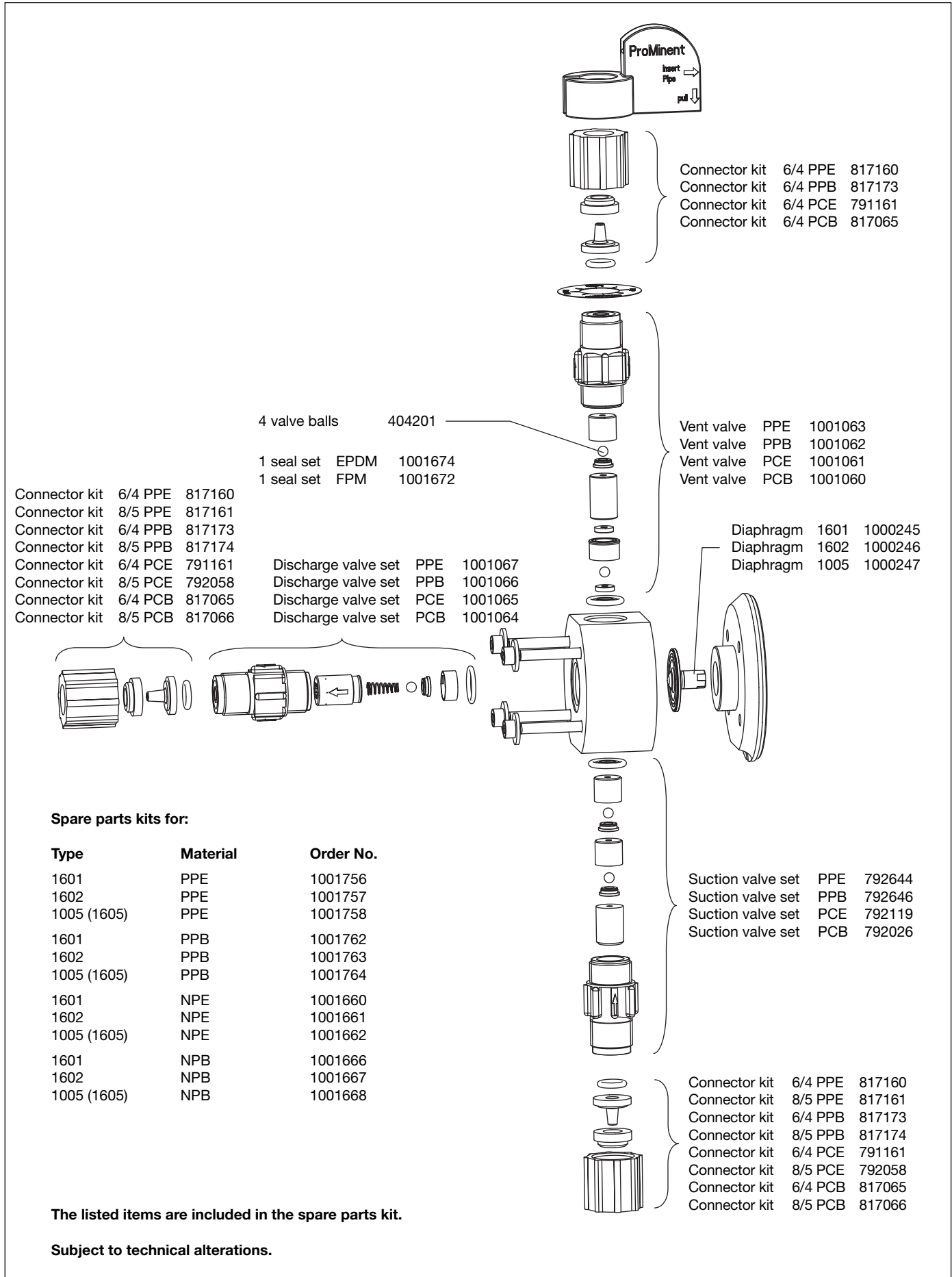



Liquid end 0708 (1008) - 0220 (0420)  
PP / NP self-degassing

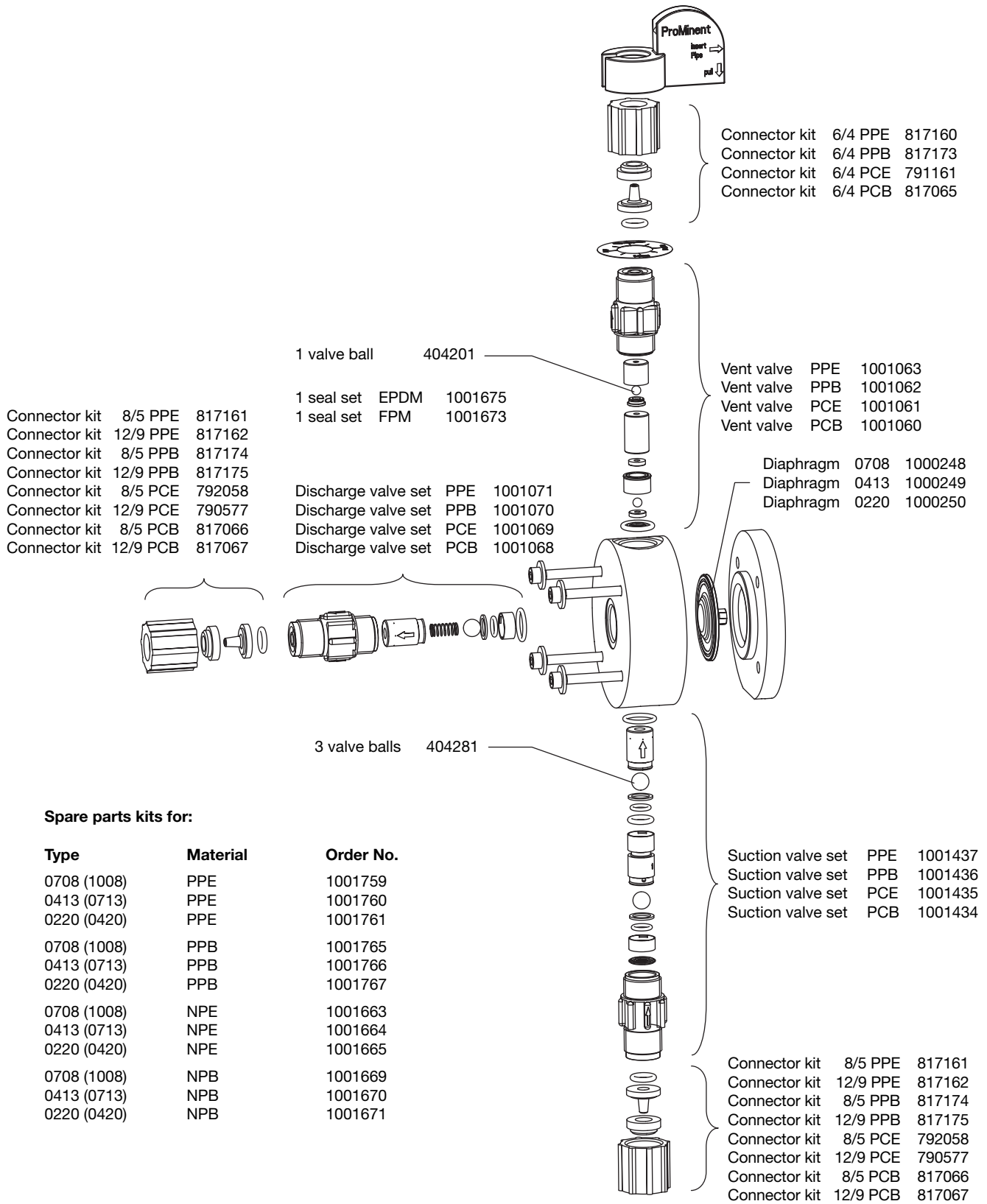

Spare parts kits for:

| Type        | Material | Order No. |
|-------------|----------|-----------|
| 0708 (1008) | PPE      | 1001759   |
| 0413 (0713) | PPE      | 1001760   |
| 0220 (0420) | PPE      | 1001761   |
| 0708 (1008) | PPB      | 1001765   |
| 0413 (0713) | PPB      | 1001766   |
| 0220 (0420) | PPB      | 1001767   |
| 0708 (1008) | NPE      | 1001663   |
| 0413 (0713) | NPE      | 1001664   |
| 0220 (0420) | NPE      | 1001665   |
| 0708 (1008) | NPB      | 1001669   |
| 0413 (0713) | NPB      | 1001670   |
| 0220 (0420) | NPB      | 1001671   |

The listed items are included in the spare parts kit.

Subject to technical alterations.

Liquid end 1000-1005 (1605)  
PVT with bleed

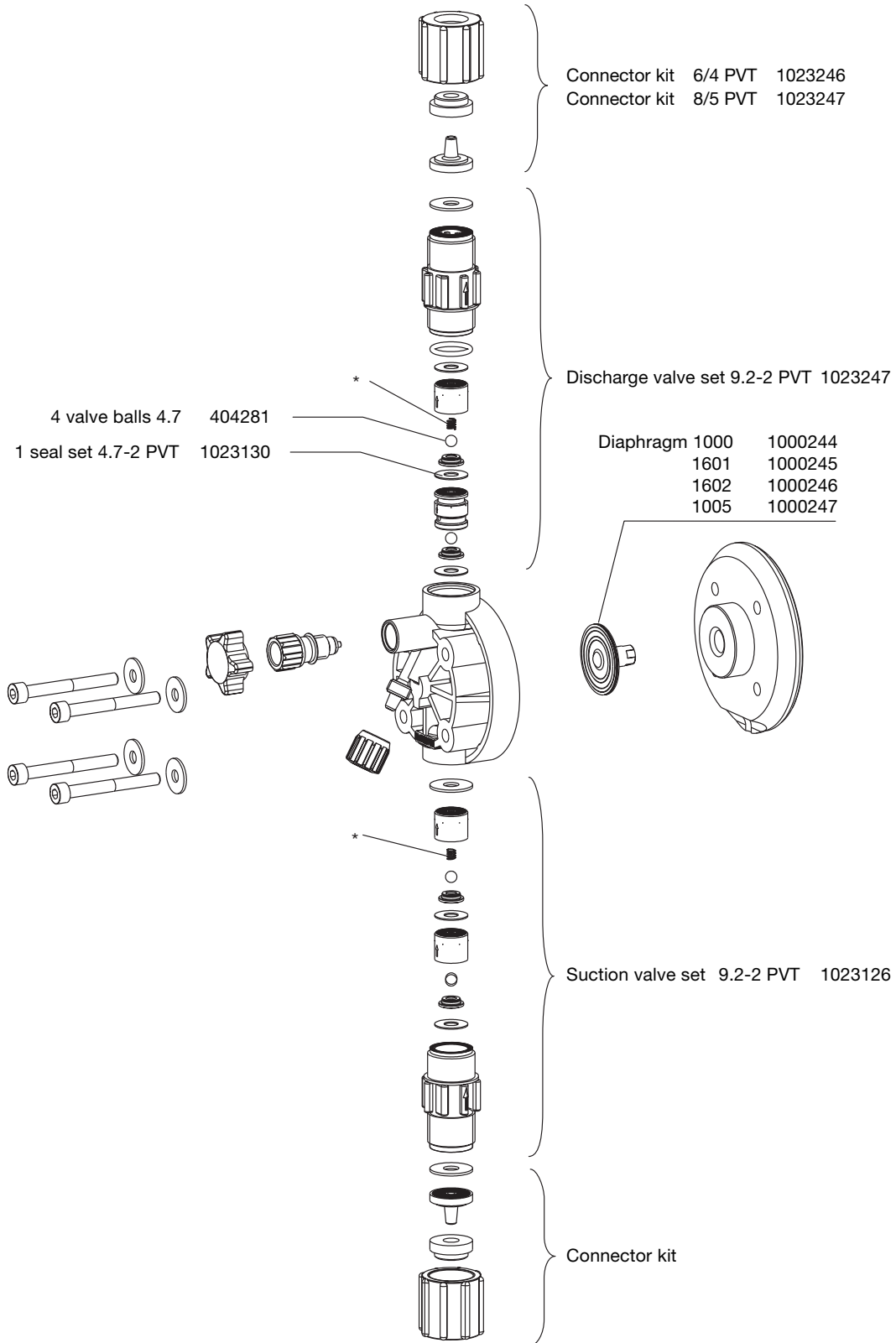

The listed items are included in the spare parts kit.

\* Customer accessories

Subject to technical alterations.

Liquid end 0708 (1008) - 0220 (0420)  
PVT with bleed

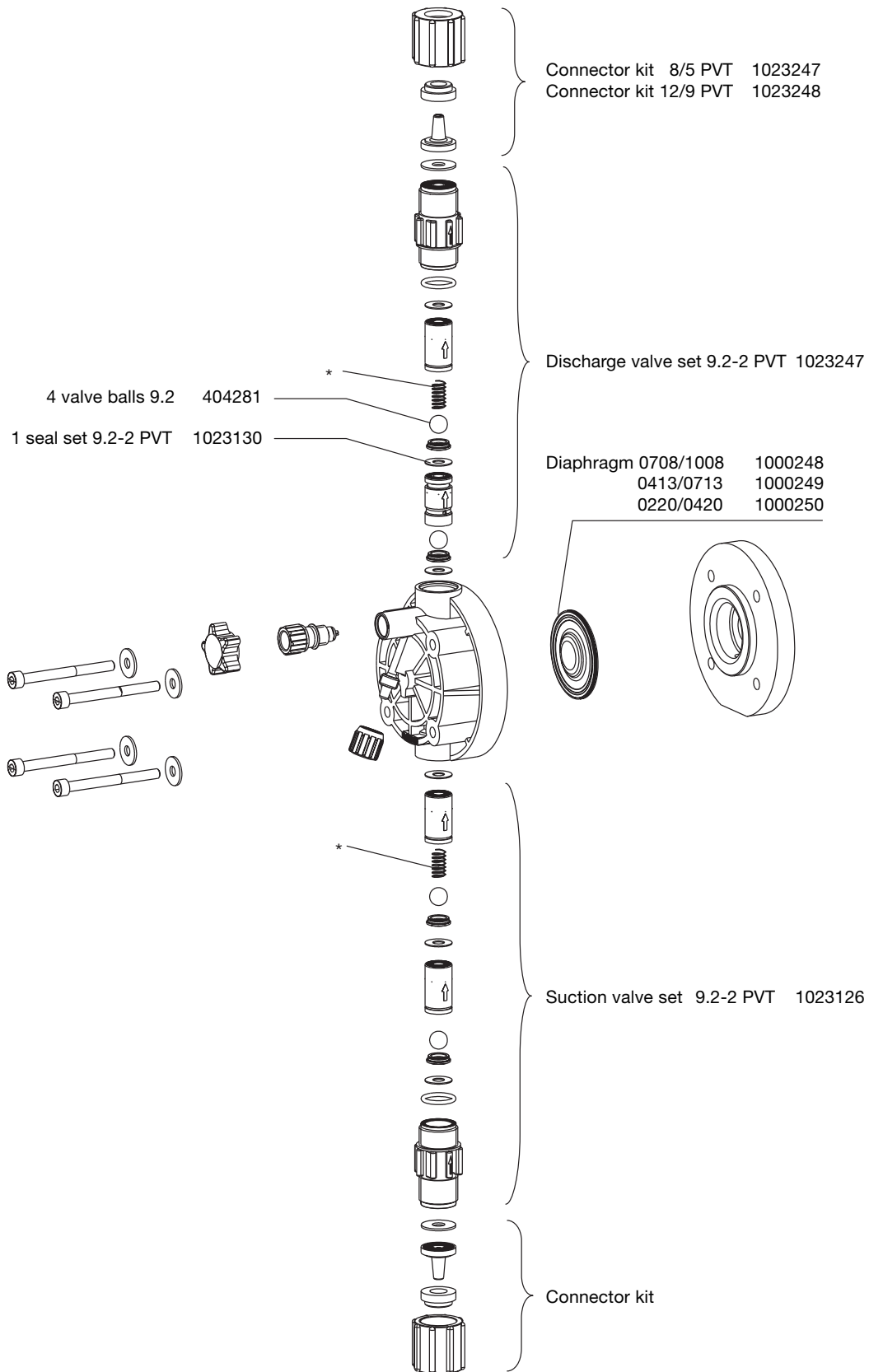

The listed items are included in the spare parts kit.  
\* Customer accessories

Subject to technical alterations.

Liquid end 0232  
PVT without bleed

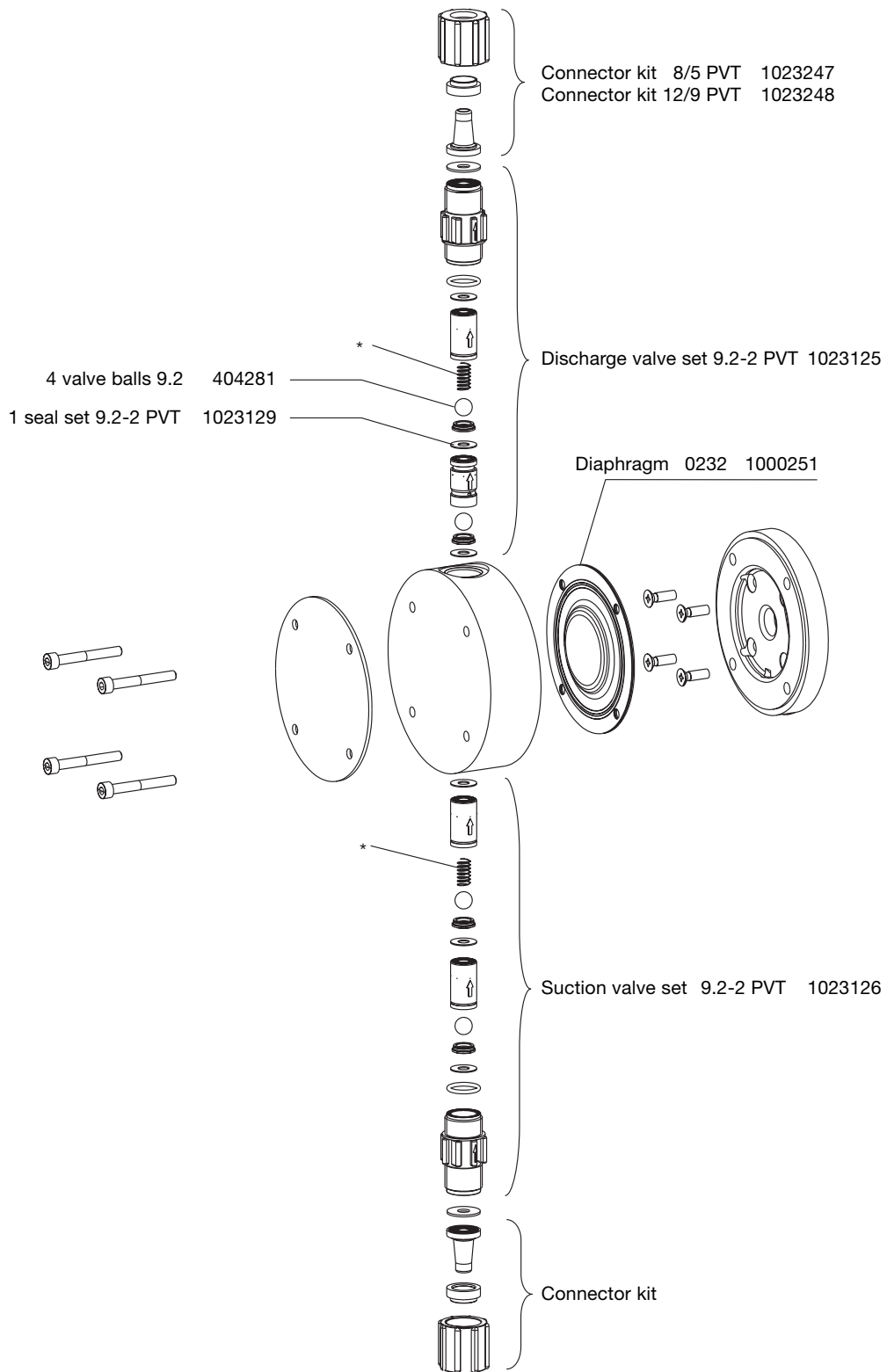

The listed items are included in the spare parts kit.

\* Customer accessories

Subject to technical alterations.

Liquid end 1000 - 1005 (1605)  
TT

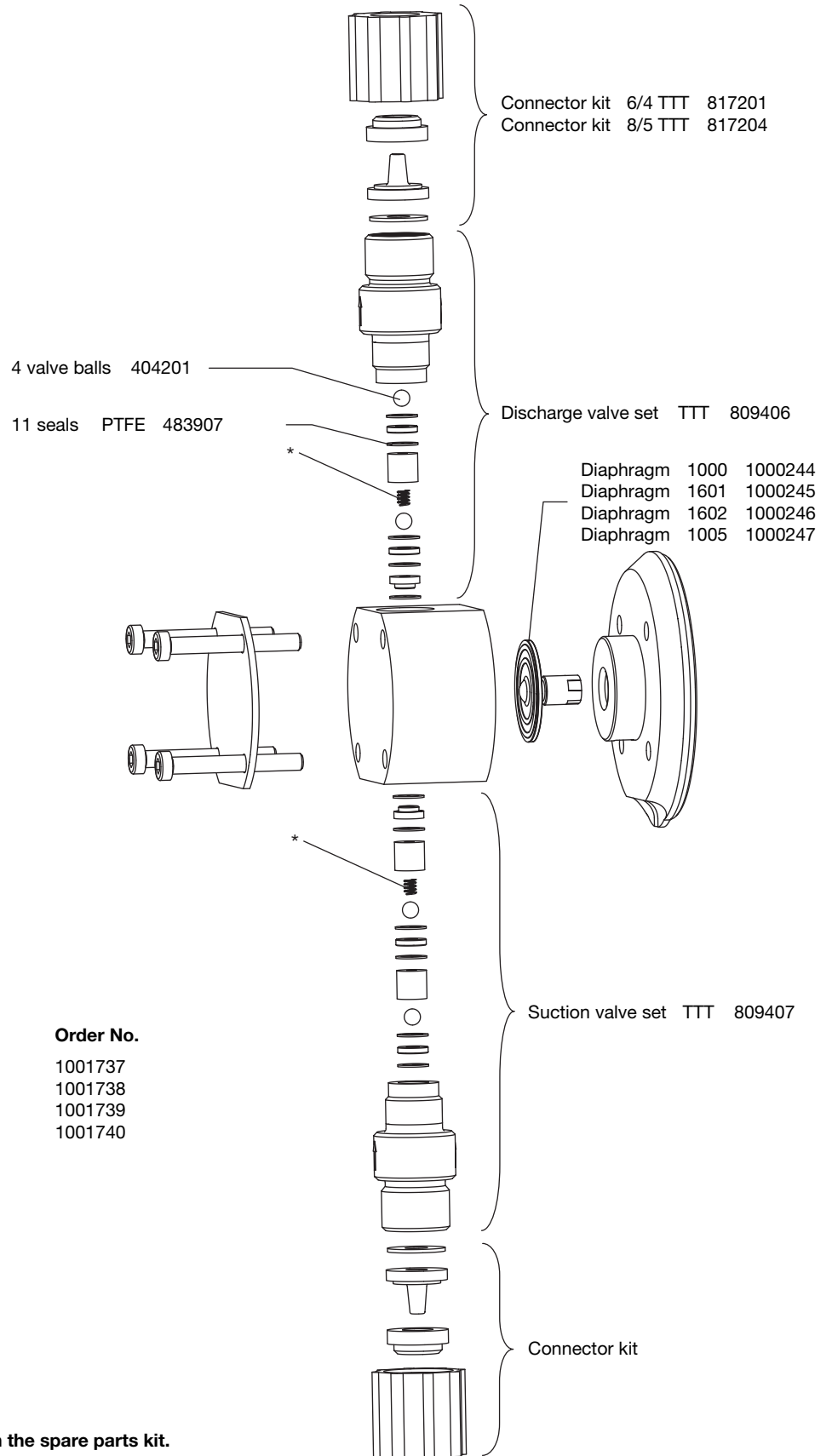

Spare parts kits for:

| Type        | Material | Order No. |
|-------------|----------|-----------|
| 1000        | TTT      | 1001737   |
| 1601        | TTT      | 1001738   |
| 1602        | TTT      | 1001739   |
| 1005 (1605) | TTT      | 1001740   |

The listed items are included in the spare parts kit.  
\* Customer accessories

Subject to technical alterations.

60\_07-104\_00\_29-04\_2

Liquid end 0708 (1008) - 0220 (0420)  
TT

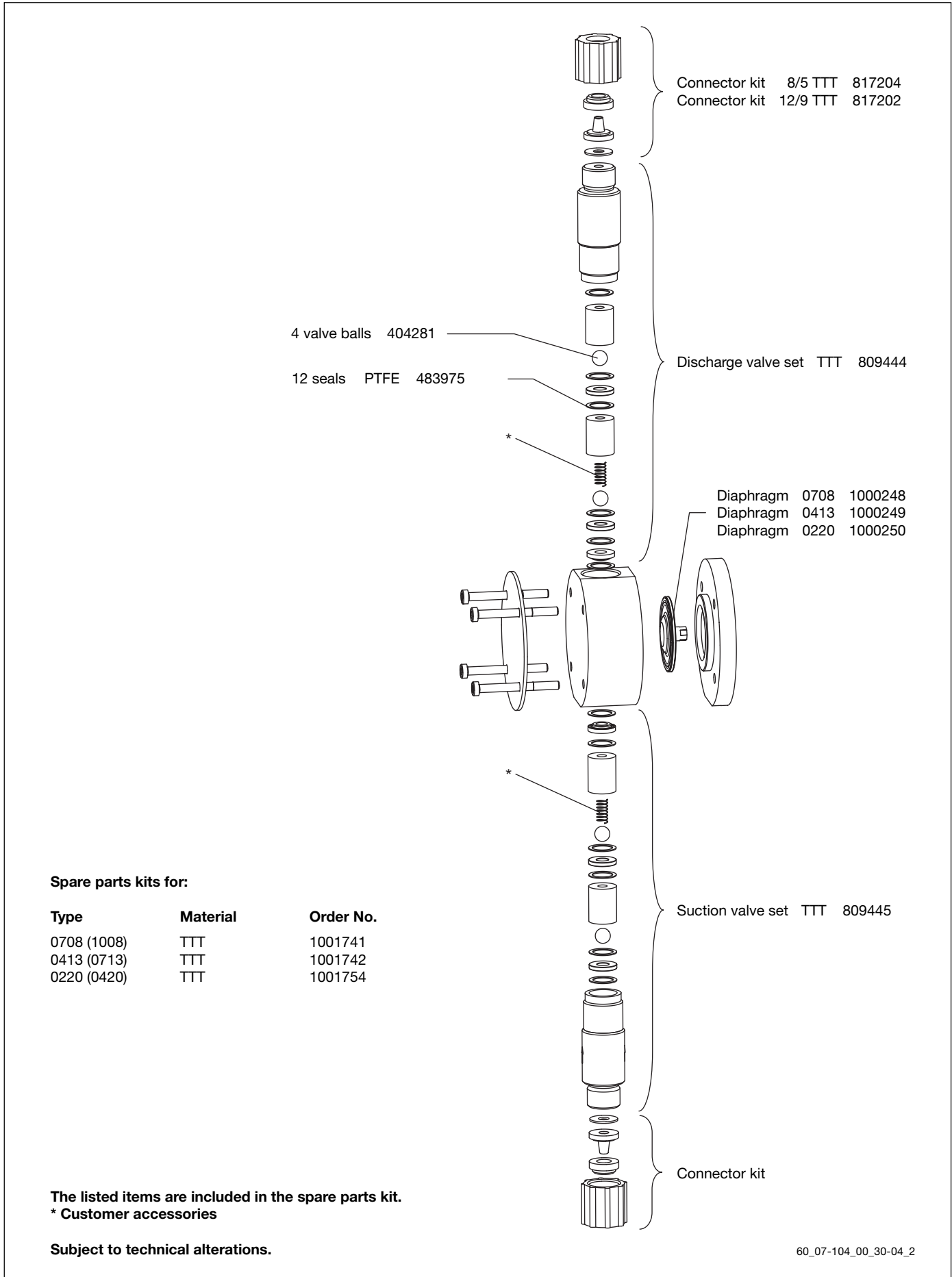

Spare parts kits for:

| Type        | Material | Order No. |
|-------------|----------|-----------|
| 0708 (1008) | TTT      | 1001741   |
| 0413 (0713) | TTT      | 1001742   |
| 0220 (0420) | TTT      | 1001754   |

The listed items are included in the spare parts kit.  
\* Customer accessories

Subject to technical alterations.

60\_07-104\_00\_30-04\_2

Liquid end 0232  
TT

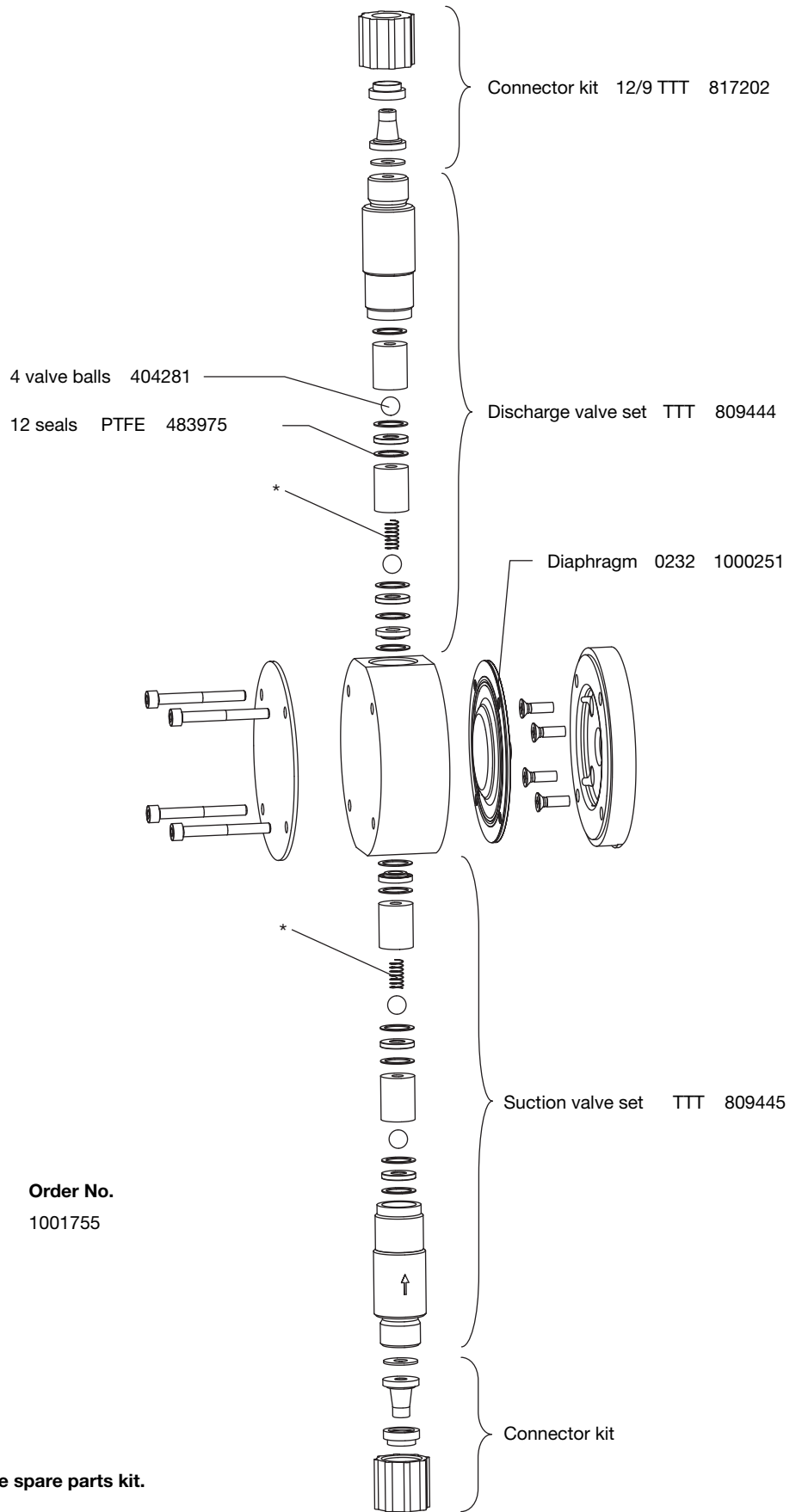

Spare parts kits for:

| Type | Material | Order No. |
|------|----------|-----------|
| 0232 | TTT      | 1001755   |

The listed items are included in the spare parts kit.  
\* Customer accessories

Subject to technical alterations.

60\_07-104\_00\_35-04\_2

Liquid end 1000 - 1005 (1605)  
SS

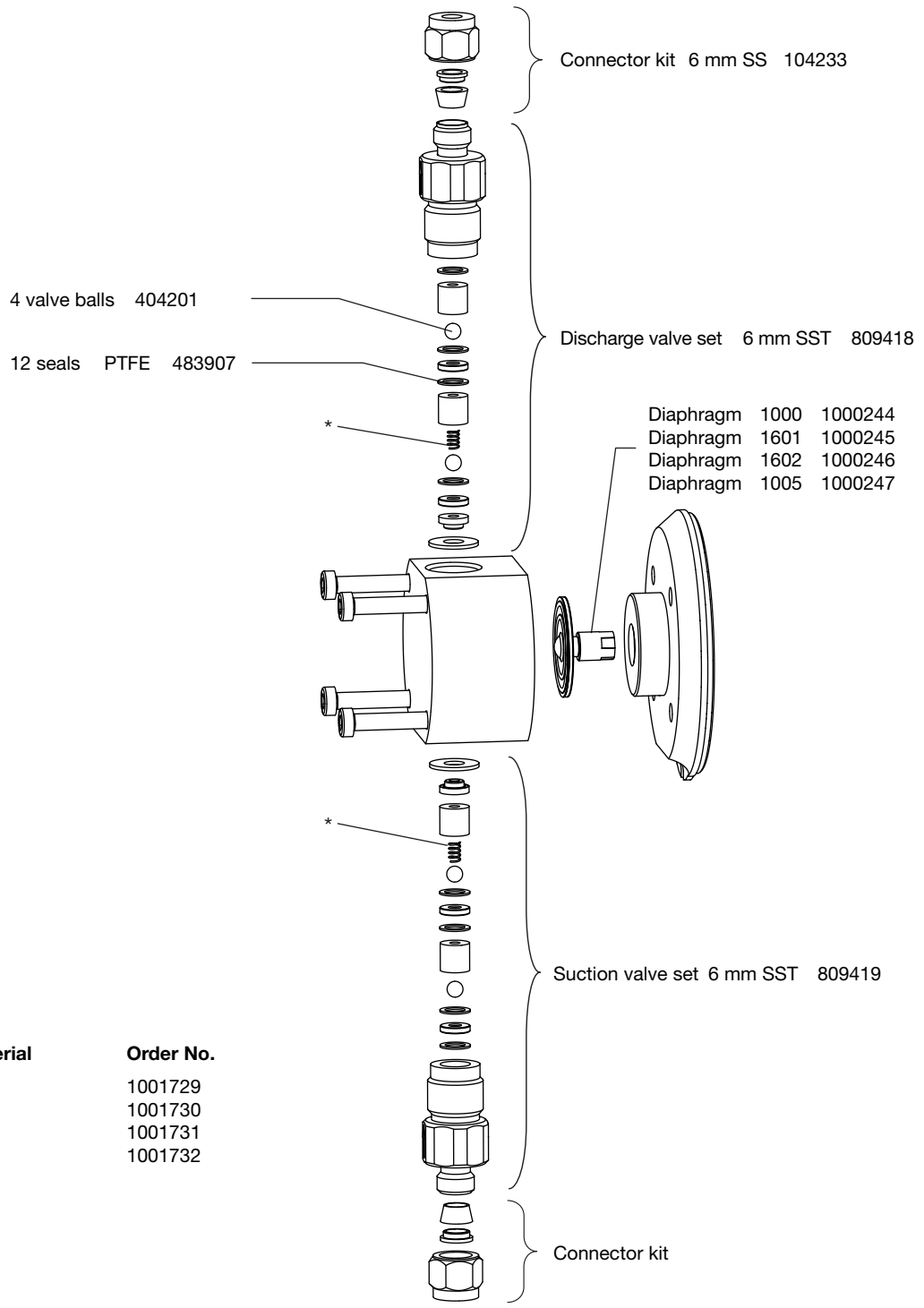

Spare parts kits for:

| Type        | Material | Order No. |
|-------------|----------|-----------|
| 1000        | SST      | 1001729   |
| 1601        | SST      | 1001730   |
| 1602        | SST      | 1001731   |
| 1005 (1605) | SST      | 1001732   |

The listed items are included in the spare parts kit.  
\* Customer accessories

Subject to technical alterations.



Liquid end 0708 (1008) - 0220 (0420)  
SS

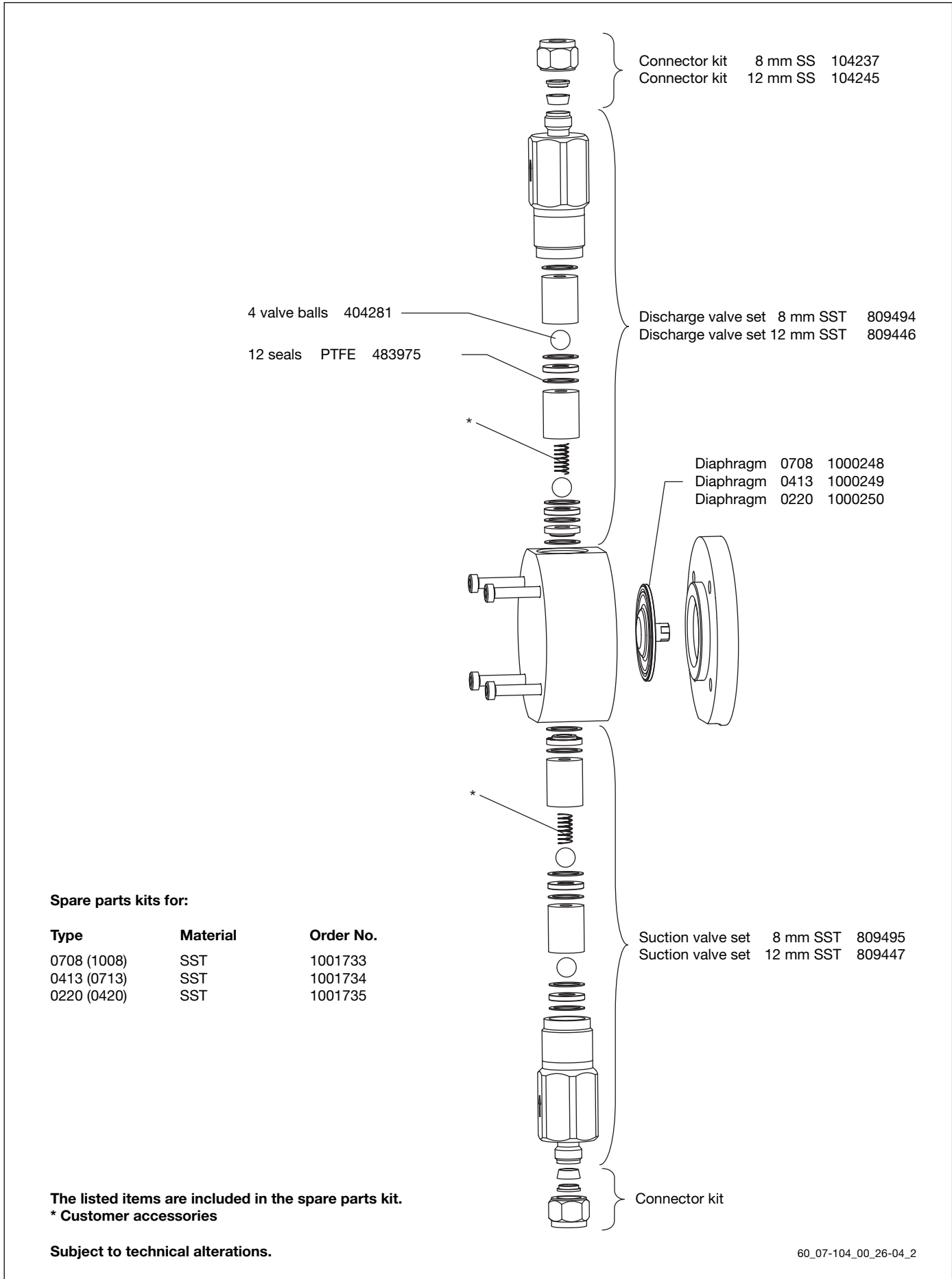

Connector kit 8 mm SS 104237  
Connector kit 12 mm SS 104245

4 valve balls 404281

12 seals PTFE 483975

Discharge valve set 8 mm SST 809494  
Discharge valve set 12 mm SST 809446

Diaphragm 0708 1000248  
Diaphragm 0413 1000249  
Diaphragm 0220 1000250

Spare parts kits for:

| Type        | Material | Order No. |
|-------------|----------|-----------|
| 0708 (1008) | SST      | 1001733   |
| 0413 (0713) | SST      | 1001734   |
| 0220 (0420) | SST      | 1001735   |

Suction valve set 8 mm SST 809495  
Suction valve set 12 mm SST 809447

Connector kit

The listed items are included in the spare parts kit.  
\* Customer accessories

Subject to technical alterations.

Liquid end 0232  
SS

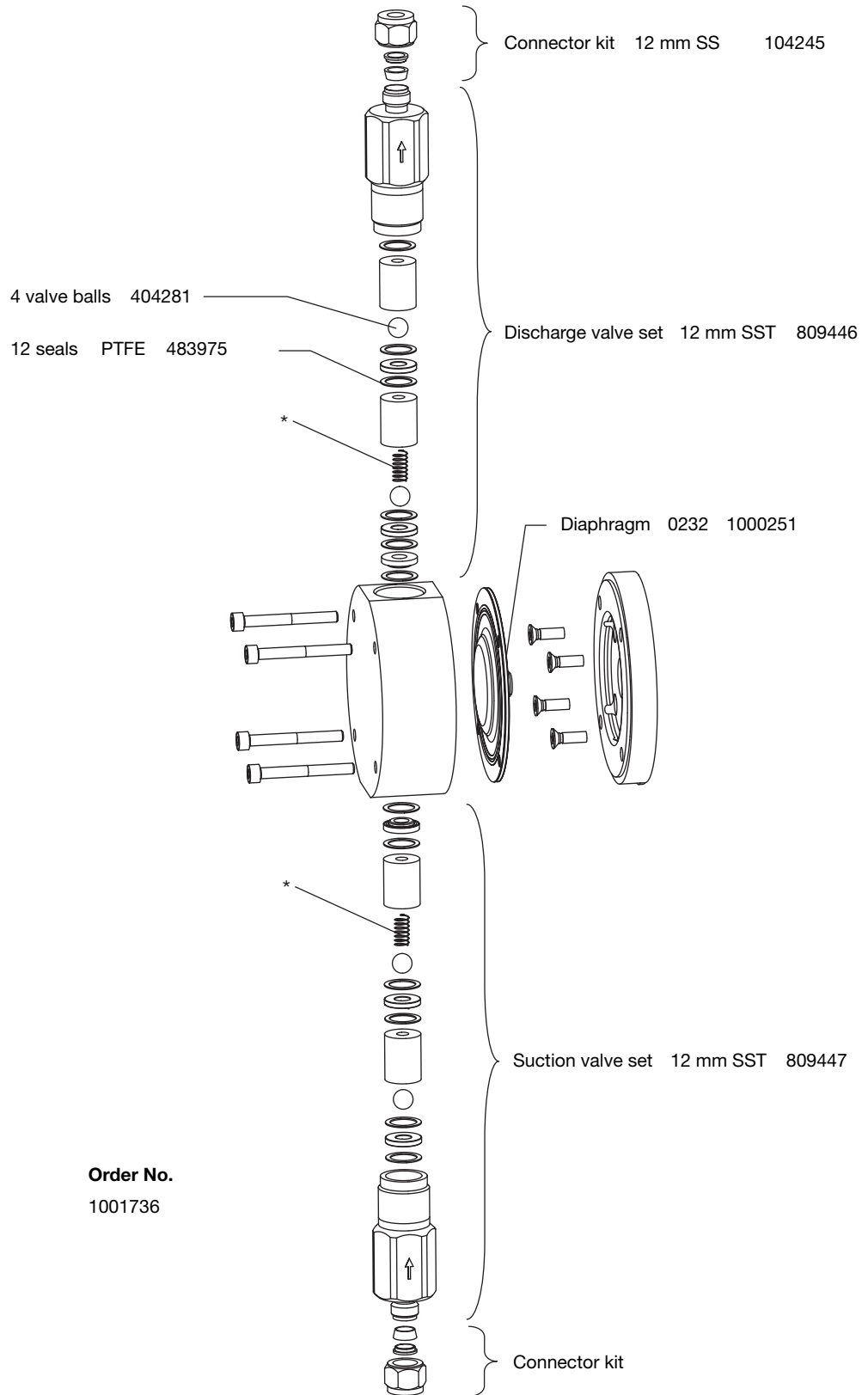

Spare parts kits for:

| Type | Material | Order No. |
|------|----------|-----------|
| 0232 | SST      | 1001736   |

The listed items are included in the spare parts kit.  
\* Customer accessories

Subject to technical alterations.

60\_07-104\_00\_36-04\_2

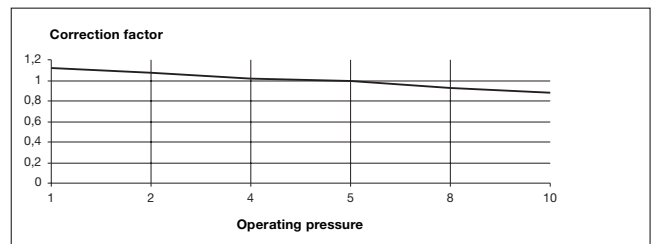
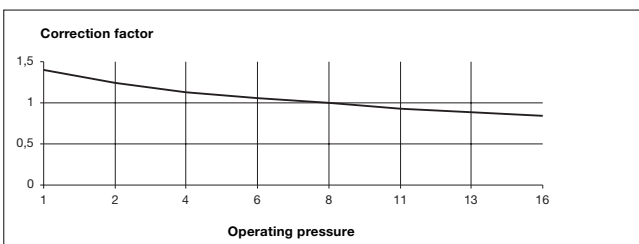
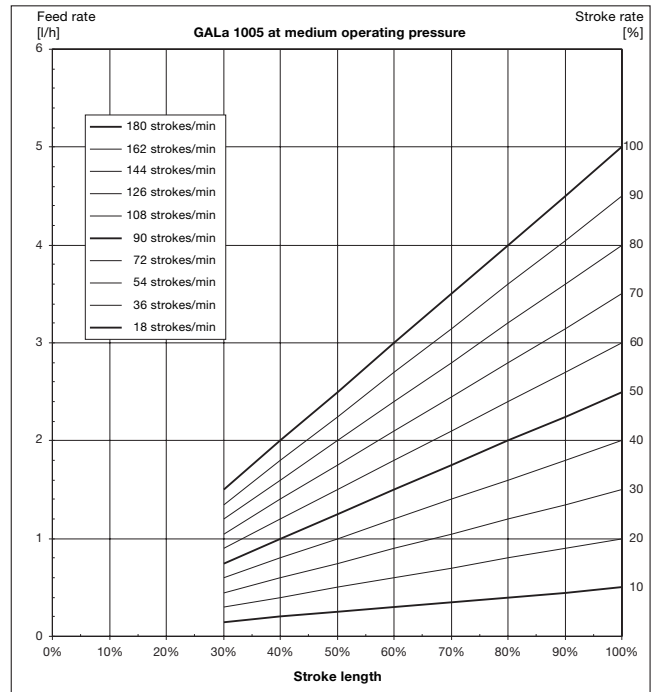
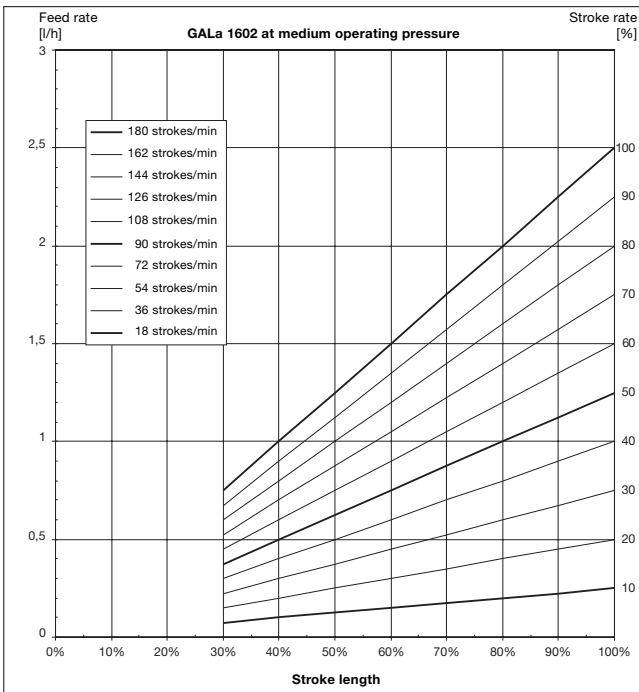
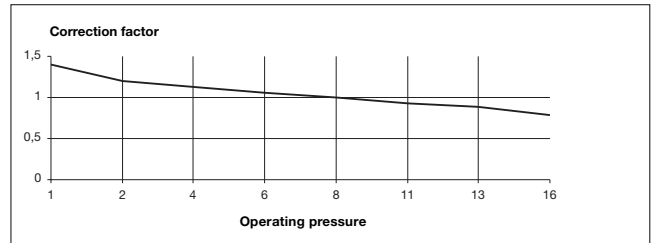
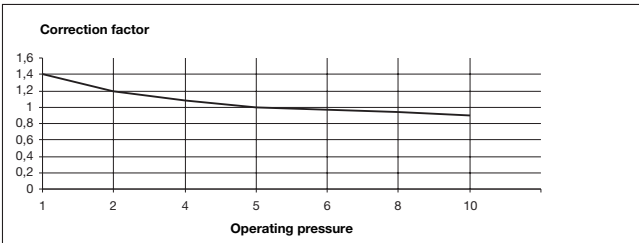
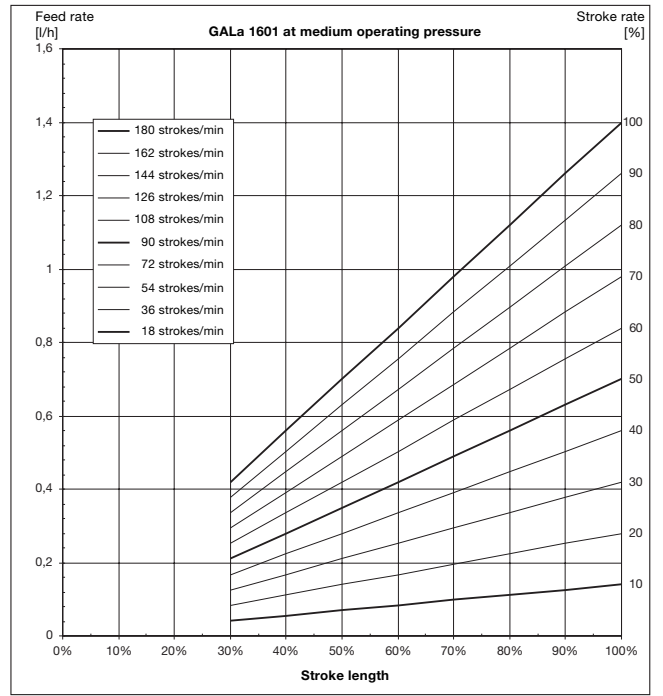
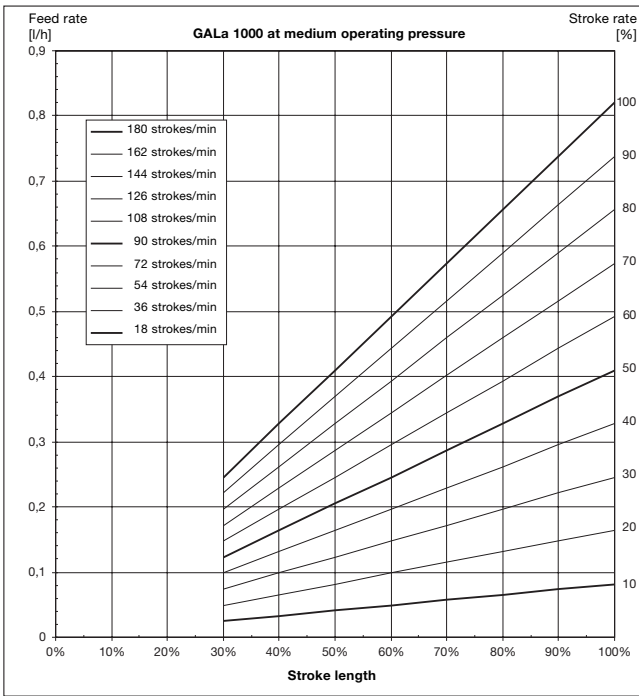

# Feed rate settings diagrams

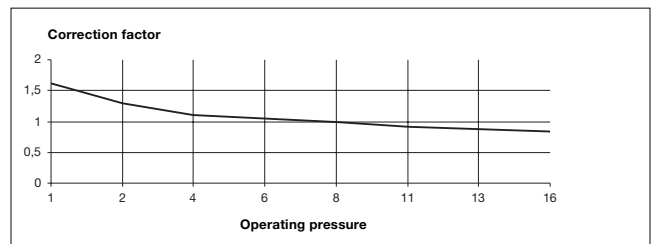
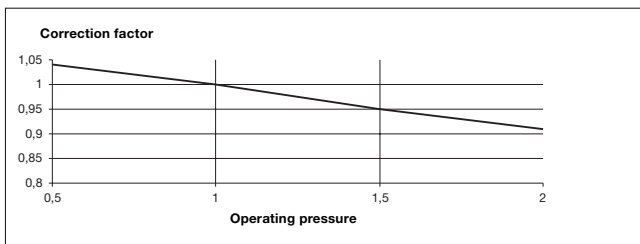
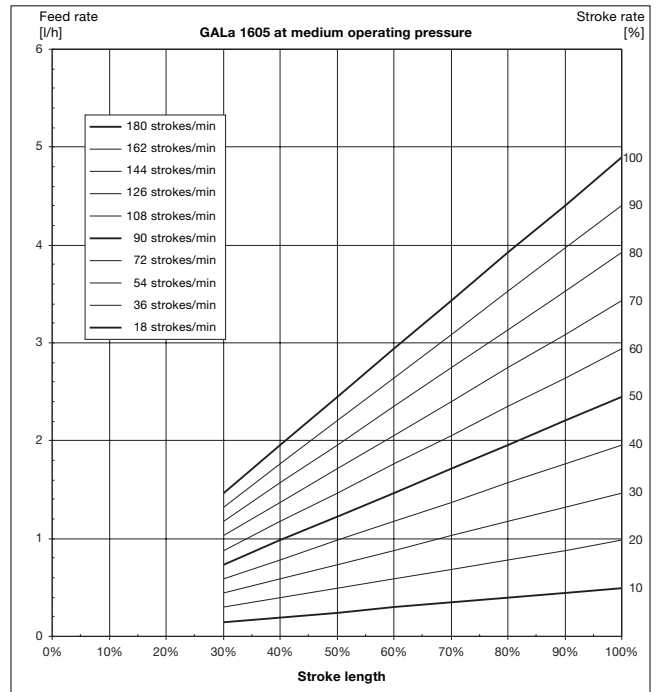
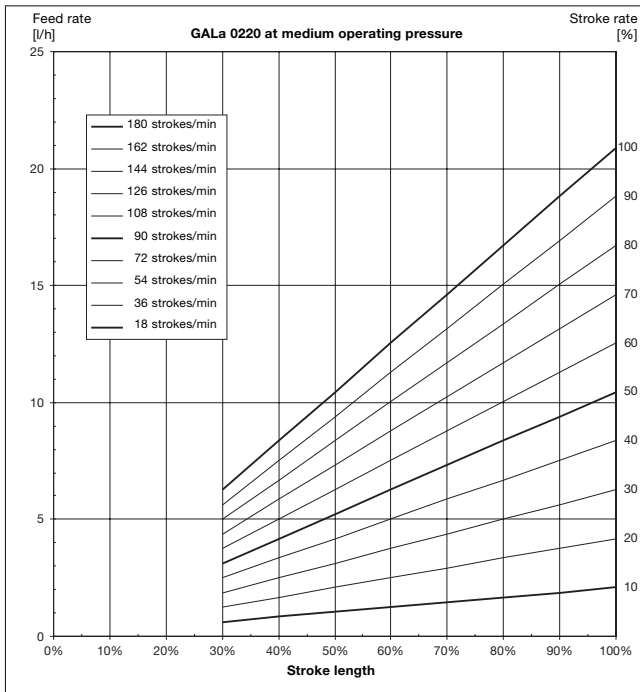
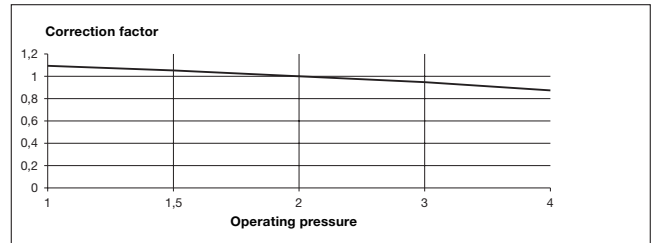
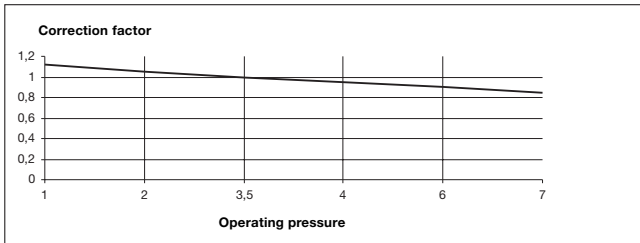
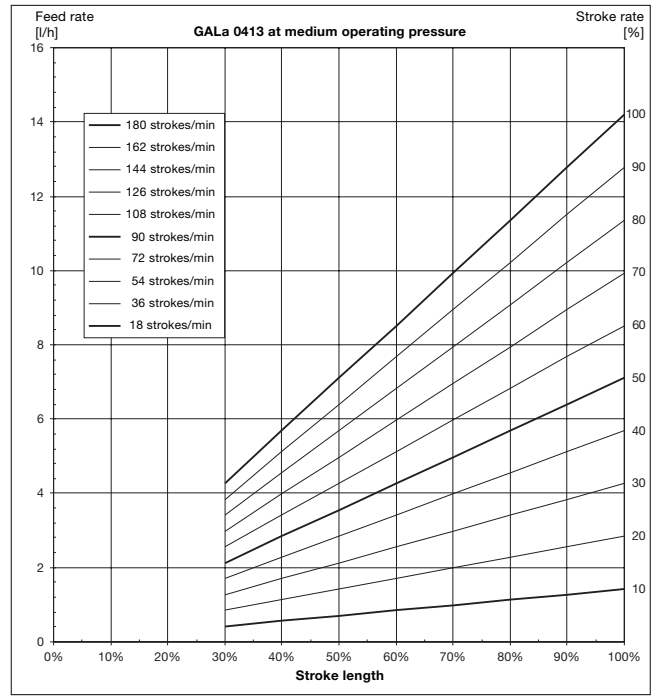
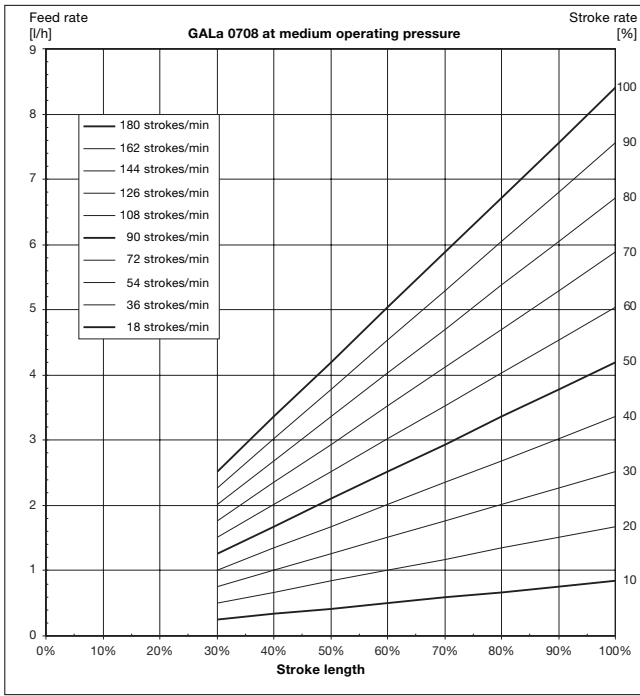

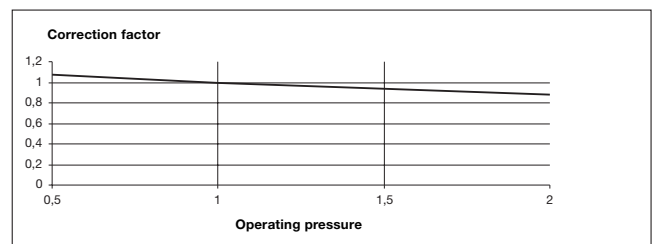
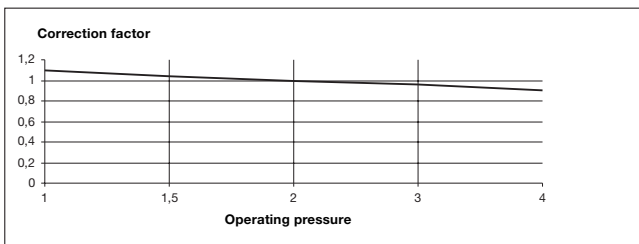
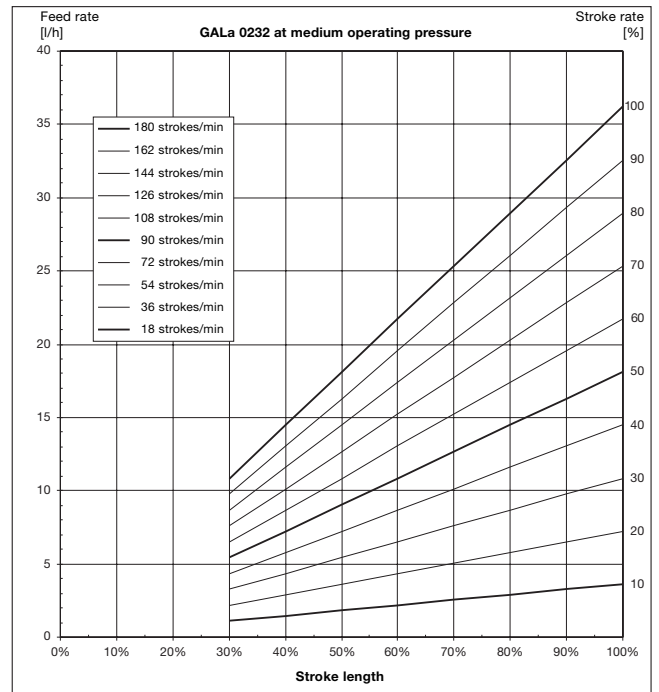
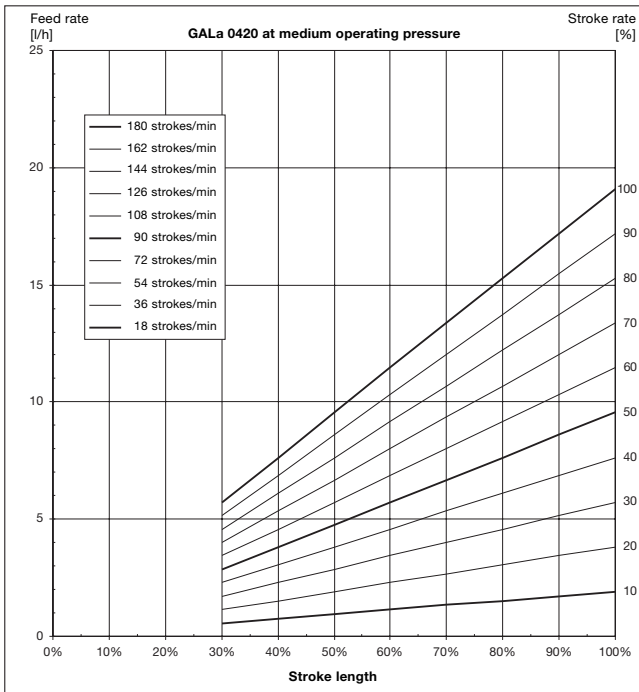
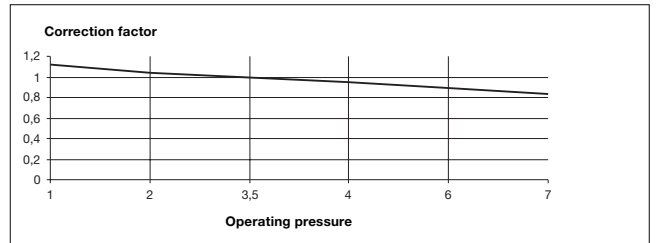
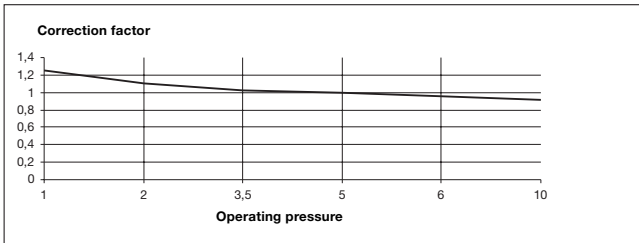
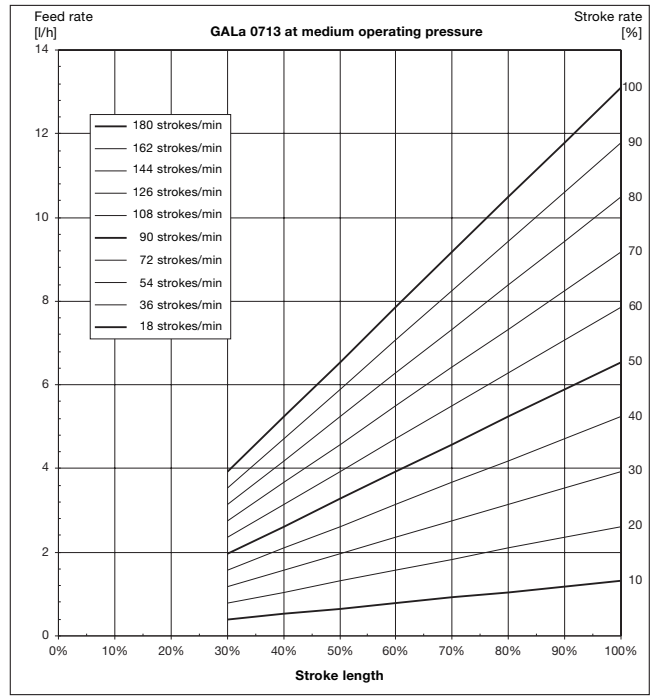
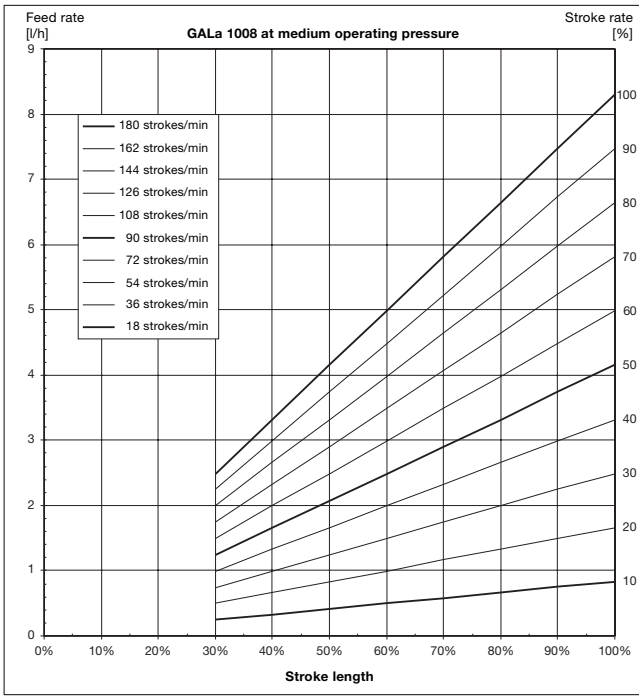

## EC Declaration of Conformity

We,

**ProMinent Dosiertechnik GmbH**  
**Im Schuhmachergewann 5 - 11**  
**D - 69123 Heidelberg**

hereby declare that, on the basis of its functional concept and design and in the version brought into circulation by us, the product specified in the following complies with the relevant, fundamental safety and health stipulations laid down by EC regulations.

Any modification to the product not approved by us will invalidate this declaration.

Product description : *Metering pump, series Gamma L*

Product type : *GALa*

Serial number : *see type identification plate on device*

Relevant EC directives : *EC - machine directive 98/37/EC*  
*EC - low voltage directive 73/23/EEC*  
*EC - EMC - directive (89/336/EEC) subsequently 92/31 EEC*

Harmonised standards used,  
in particular : *DIN EN 292-1, DIN EN 292-2, DIN EN 809*  
*DIN EN 60335-1, DIN EN 60335-2-41, DIN EN 50106*  
*DIN EN 50081-1/2, DIN EN 55011, DIN EN 61000-3-3*  
*DIN EN 50082-1/2, DIN EN 61000-4-2/3/4/5/6/11*

National standards and other  
technical specifications used,  
in particular : *DIN VDE 0700 T1*  
*DIN VDE 0700 T41*  
*DIN VDE 0700 T500*  
*IEC 1000-3-3, IEC 1000-4-2/3/4/5/6/11*

Date/manufacturer's signature :

*02. Nov 99*

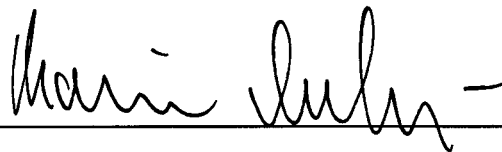

The undersigned :

*Dr. Rainer V. Dulger, Executive Vice President R&D and Production*